

Z
695.66
.L63

A
NONBOOK
CATALOGING SAMPLER

David V. Loertscher

025.347

L824n

A NONBOOK CATALOGING SAMPLER

by

David V. Loertscher
Purdue University

applications of library science, volume 5

Armadillo Press
Austin, Texas

APPLICATIONS OF LIBRARY SCIENCE, VOLUME 5

C. Boyer, Series Editor

First Edition, 1975

First Printing, 1975

Copyright © 1975, by David V. Loertscher

All rights reserved

ISBN: 0-912556-04-8

Library of Congress Cataloging in Publication Data

Loertscher, David V 1940-
A nonbook cataloging sampler.

(Applications of library science; v. 5)

"The examples have been chosen to illustrate the rules in Nonbook materials; the organization of integrated collections, 1st ed., by Jean Riddle Weihs, Shirley Lewis, and Janet Macdonald, Canadian Library Association, 1973."

Includes index.

1. Cataloging of non-book material. I. Title.
II. Weihs, Jean Riddle. Nonbook materials : the organization of integrated collections.

Z695.66.L63 025.3'47 75-11811

ISBN 0-912556-04-8

Manufactured in the United States

Armadillo Press
Box 8131
University Station
Austin, Texas 78712

THE LIBRARY
BRIGHAM YOUNG UNIVERSITY
PROVO, UTAH

PREFACE

As a workbook for beginning and intermediate cataloging students, A NONBOOK CATALOGING SAMPLER presents 100 carefully chosen titles which are useful in introducing the rules for cataloging all types of audiovisual materials. The examples have been chosen to illustrate the rules in *Nonbook Materials; The Organization of Integrated Collections*, 1st ed., by Jean Riddle Weihs, Shirley Lewis, and Janet Macdonald, Canadian Library Association, 1973, hereafter referred to as Weihs.

For each audiovisual title, the SAMPLER includes the substitute for the title page and sufficient notes on the format for the student to prepare the main entry catalog card.

As a basic teaching aid, the SAMPLER allows the teacher to present a wide variety of cataloging problems for audiovisual materials without incurring the expense of assembling a practice cataloging collection.

Each example is based on one or more actual titles found by the author in school, public or academic libraries, and each has been chosen to represent the types of materials in a typical collection as well as particular cataloging problems. Names of titles, publishing companies, authors, and performers are similar but not necessarily the names of actual titles, corporate bodies, or persons.

DIRECTIONS FOR USE

Arrangement: The 100 examples which follow are organized into sections by type of media and follow the order of the cataloging manual: *Nonbook Materials; The Organization of Integrated Collections*. Within each type of media, there is some progression of difficulty for the cataloger, the easiest examples are generally presented first. The example has been placed on the left side so that the student may use the blank page on the right to construct the main entry card.

Suggested guide for constructing main entry cards when the Weihs manual is used as the authority: Make a main entry card for each item in accordance with the rules given by Weihs. Follow Weihs' preferred rules when several alternatives are given. Use the examples in Weihs as well as the exposition of the rules to guide you in constructing the main entry card. Where there is no rule or example for a particular problem, a similar problem in another medium may give a clue for resolving the dilemma. The *Anglo American Cataloging Rules* should also be used when no rule is found in Weihs.

Classification numbers: Assign Dewey Decimal Classification numbers using either Edition 18 or the 10th Abridged Edition, according to your instructor's wishes. Numbers should be constructed using the description of the content for each item. Since the item is not available for an examination of the subject matter, a probable classification number or perhaps several alternative numbers should be given.

Subject headings: Assign subject headings using either the *Sears List of Subject Headings* (10th ed.) or the *Library of Congress List of Subject Headings* (7th or 8th ed.) as directed by your instructor. As with classification, probable headings should be assigned since an in-depth examination of the content is impossible.

TABLE OF CONTENTS

Audiorecords.....	1
Charts	15
Dioramas	19
Filmstrips	20
Flash Cards	28
Games	31
Globes	35
Kits	39
Machine Readable Data Files	47
Maps	49
Microforms.....	55
Microscope Slides	59
Models	62
Motion Pictures	68
Pictures	74
Realia	82
Slides	87
Transparencies	92
Videorecords	97

Album cover title:

Notes on format:

E.B. White Reads

The album contains four 12"
mono. records with matrix
numbers Z4RM-016-Z4RM-023

CHARLOTTE'S
WEB

Roadways of Sound
Cover by Garth Williams

Reverse side of album cover:

E.B. WHITE READS

CHARLOTTE'S WEB

Produced and Directed by Joe Berk
Recording Engineer: E.F. Auchter
Editing and Re-Mastering: Stephen B. Fassett
Photograph: Donald E. Johnson
Cover: Garth Williams
Design: Hugh Price

© 1962

Album cover title:

954

*THE
SONG
OF
PAUL BUNYAN
AND
TONY BEAVER*

Written and read by
Ennis Rees

TALKING ARTS

Notes on format:

A single 33 1/3 rpm record-12"-
mono.

Label on record gives the same
title information as the reverse
side of the album cover.

Note on album cover:

The Song of Paul Bunyan and
Tony Beaver is an attempt to
make a poem, a kind of comic
American epic, from the prose
source materials of the Paul
Bunyan legend. I have chosen a
number of the best tall tales
concerning Paul Bunyan, and
others concerning his southern
counterpart, Tony Beaver, and
given them an integrated
structure in which Paul and Tony
meet and discover what they
have in common. The verse line
has four major stresses and is
unrhyming.

—Ennis Rees

Reverse side of album cover:

TALKING ARTS TA954

©1964

*THE SONG OF PAUL BUNYAN
AND TONY BEAVER*

Written and Read by Ennis Rees

Contents of the record:

Side one:

Little Paul
The Winter of the Blue Ox
Paul's Men
Dinners on the Big Onion
Making Geography
The Spring of the Rain That Came Up From China

Side two:

Tony Beaver and Little Buddy
The Wonderful Dewdrop
The Big Music
The Contest
The World's Funny-Bone

Album cover title:

Notes on format:

One 33 1/3 stereo record. 12"

From the Sound Track of the Motion Picture

RODGERS AND HAMMERSTEIN'S

OKLAHOMA

Ropitol Records Stereo WAO 595
copyright 1955 Ropitol Records, Inc.

Reverse side of album cover:

Oklahoma

Gordon MacRae—Gloria Grahame
Gene Nelson—Charlotte Greenwood
James Whitmore—Shirley Jones
Rod Steiger—Jay C. Flippen

Music by:
RICHARD RODGERS

Book and Lyrics by:
OSCAR HAMMERSTEIN II

Produced by Arthur Hornblow, Jr.

Directed by Fred Zinnemann

Musical arrangements by Robert Russell Bennett
Music conducted and supervised by Jay Blackton
Music coordinator: Robert Helfer

Cassette case:

(front)

(back)

JUDY COLLINS
COLORS OF THE NIGHT
THE BEST OF JUDY COLLINS

TZ 55030

**COLORS OF THE NIGHT
THE BEST OF JUDY COLLINS**

Side one:

Someday Soon
Ian Tyson
Since You Asked
Judy Collins
My Father
Judy Collins
Sons of
Jacques Brel
Suzanne
Leonard Cohen
Farewell to Tarwathie
Judy Collins

Side two:

Both Sides Now
Joni Mitchell
Who Knows Where the Time Goes
Sandy Denny
Sunny Goodge Street
Donovan
Albatross
Judy Collins
In My Life
Lennon-McCartney
Amazing Grace
Judy Collins

© 1972 by Zebulon Records

Side one: *Someday Soon/ Since You Asked/
My Father/ Sons of/ Suzanne/ Farewell to
Tarwathie*

© 1972 by Zebulon Records



Stereo

TZ 55030

Judy Collins/ **COLORS OF THE NIGHT
THE BEST OF JUDY COLLINS**

Album cover title:

Notes on format:

LSC-2719 Stereo

One 12" 33 1/3 record.

GREENSLEEVES

Vaughn Williams

Fantasia on "Greensleeves"
Fantasia on a Theme by Thomas Tallis
English Folk Song Suite

Coates

London Suite

Morton Gould and his orchestra

RBA
Red Seal

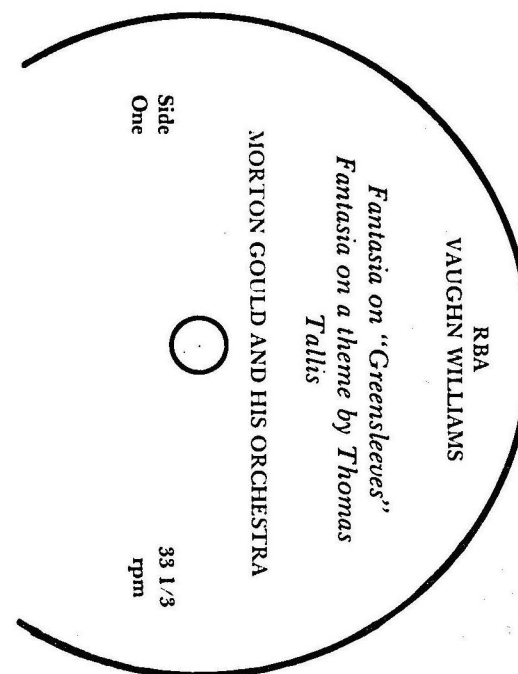

Reverse side of album cover:

GREENSLEEVES MORTON GOULD AND HIS ORCHESTRA

Vaughn Williams
Fantasia on "Greensleeves"
Harold Bennett, Flute Solo

Fantasia on a theme by Thomas Tallis
Solo Quartet: Max Pollikoff, Harold Kohon,
Walter Trampler, Harvey Shapiro

English Folk Song Suite:
Seventeen come Sunday; My Bonny Boy; Folk
Songs from Somerset

Coates
London Suite: Covent Garden; Westminster;
Knightsbridge
Harvey Shapiro, Cello Solo

c1964 RBA

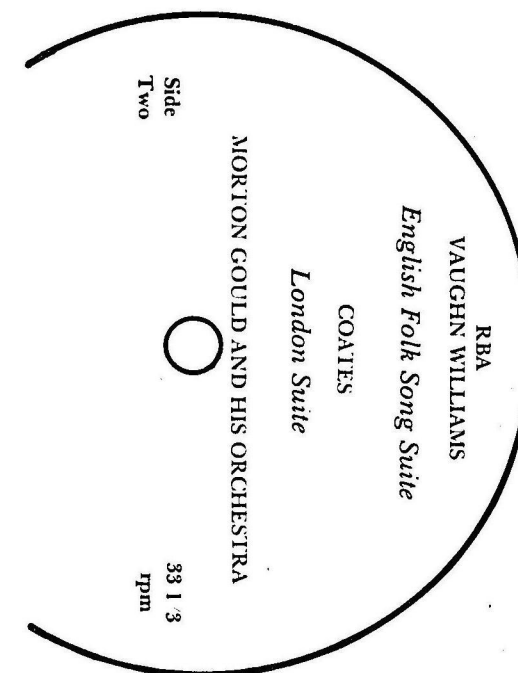

Album cover title:

LEVANT PLAYS GERSHWIN

*RHAPSODY
IN
BLUE*

CONCERTO IN F

AMERICAN IN PARIS

Colmandia VL 700

Notes on format:

A single 33 1/3 rpm record—1
monophonic.

Label on record gives exactly
same title information as
reverse side of the album cov

Reverse side of album cover:

LEVANT PLAYS GERSHWIN

Rhapsody in Blue

Oscar Levant, Piano, with the
Philadelphia Orchestra, Eugene Ormandy,
Conductor

An American in Paris

Artur Rodzinski conducting the Philharmonic
Symphony Orchestra of New York

Concerto in F for Piano and Orchestra

Oscar Levant, Piano, with Andre Kostelanetz,
conducting the Philharmonic Symphony Orchestra
of New York

Colmandia VL 700 LP
c1965

Album cover title:

Folkservice Records FA2320

AMERICAN FAVORITE BALLADS

Sung by Pete Seeger
*with 5-string banjo, guitar and 11-string
guitar*

Notes on format:

One 12" 33 1/3 rpm mono.
record.

Label on record gives exactly the
same title information as the
reverse side of the album cover

Reverse side of album cover:

AMERICAN FAVORITE BALLADS

*Sung by Pete Seeger with 5-string banjo,
guitar and 11-string guitar*

Down in the Valley
Mary, Don't You Weep
The Blue Tail Fly
Yankee Doodle
Cielito Lindo
Buffalo Girls
The Wabash Cannon Ball
So Long It's Been Good To Know You
Skip to my Lou
The Wagoner's Lad
The Wreck of the Old '97
Old Dan Tucker
I Ride an Old Paint
Frankie and Johnny
On Top of Old Smoky
The Big Rock Candy Mountain
Home on the Range

Descriptive notes are inside pocket c1957

Album cover title:

BRUNO WALTER

RBA
STEREO
Y30314

BEETHOVEN

SYMPHONY NO. 5

Radio City Symphony Orchestra

SCHUBERT

SYMPHONY NO. 8 (UNFINISHED)

New Jersey Philharmonic

Notes on format:

One 12" 33 1/3 rpm stereo
record in jacket.

Label on record gives exactly the
same title information as the
reverse side of the album cover.

Reverse side of album cover:

Side 1:

*SCHUBERT: SYMPHONY NO. 8 IN B MINOR
(UNFINISHED)*

BRUNO WALTER conducting the
NEW JERSEY PHILHARMONIC

- I. Allegro moderato
- II. Andante con moto

Side 2:

*BEETHOVEN: SYMPHONY NO. 5 IN C MINOR,
OP. 67*

BRUNO WALTER conducting the
RADIO CITY SYMPHONY ORCHESTRA

- I. Allegro con brio
- II. Andante con moto
- III. Scherzo: Allegro
- IV. Finale

*Library of Congress catalog card numbers
77-7577656 and 70-9856545 apply to Y30314*

Produced by John McClure

Tape cover title:

SERKIN/ORMANDY

THE PHILADELPHIA ORCHESTRA

BRAHMS: PIANO CONCERTO

NO. 1 IN D MINOR

Colmandia VL 5704

Notes on format:

One 7" reel-to-reel stereo tape recording—7 1/2 ips.

Enclosed is a small pamphlet entitled: "The Complete Musician; An Appreciation of Rudolf Serkin" by Irving Kolodin. Reprinted from *Horizon* magazine.

Label on reel gives exactly the same title information as the notes inside the tape recording cover.

Listed as new in the 1962 Colmandia catalog.

Notes inside tape cover:

**BRAHMS: Concerto in D Minor
for Piano and Orchestra, Op. 15**

Rudolf Serkin, Pianist

The Philadelphia Orchestra, Eugene Ormandy,
conductor

Side 1:

Maestoso

Side 2:

Rondo: Allegro Non Troppo

Album cover title:

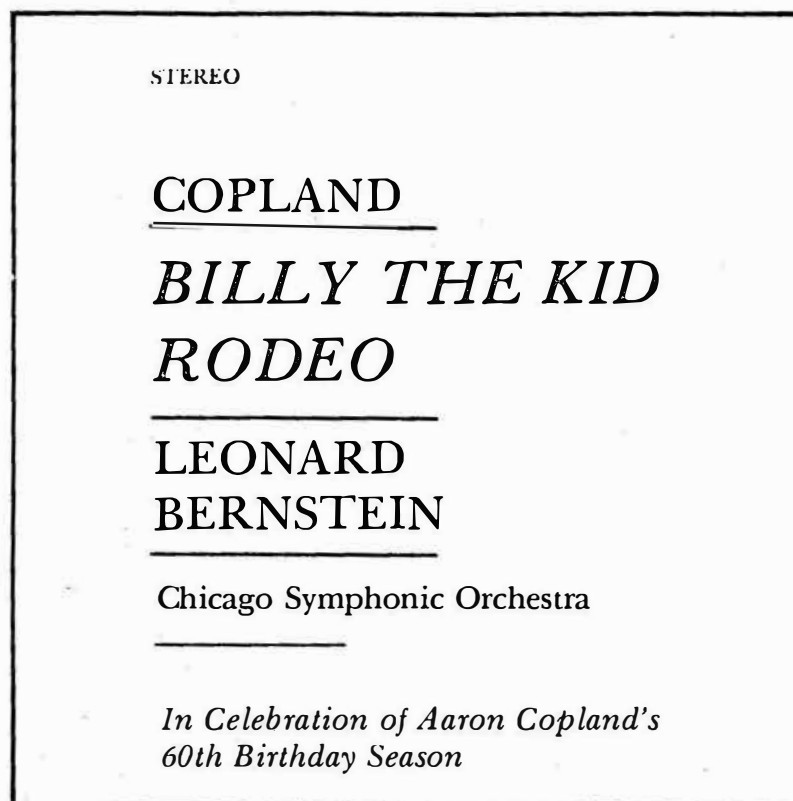

Notes on format:

Bamden Records gave year of production to the Library of Congress as 1960.



Reverse side of album cover:

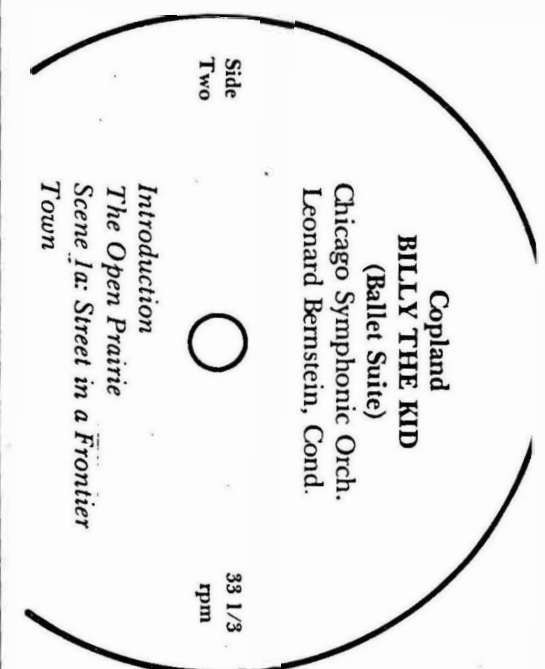
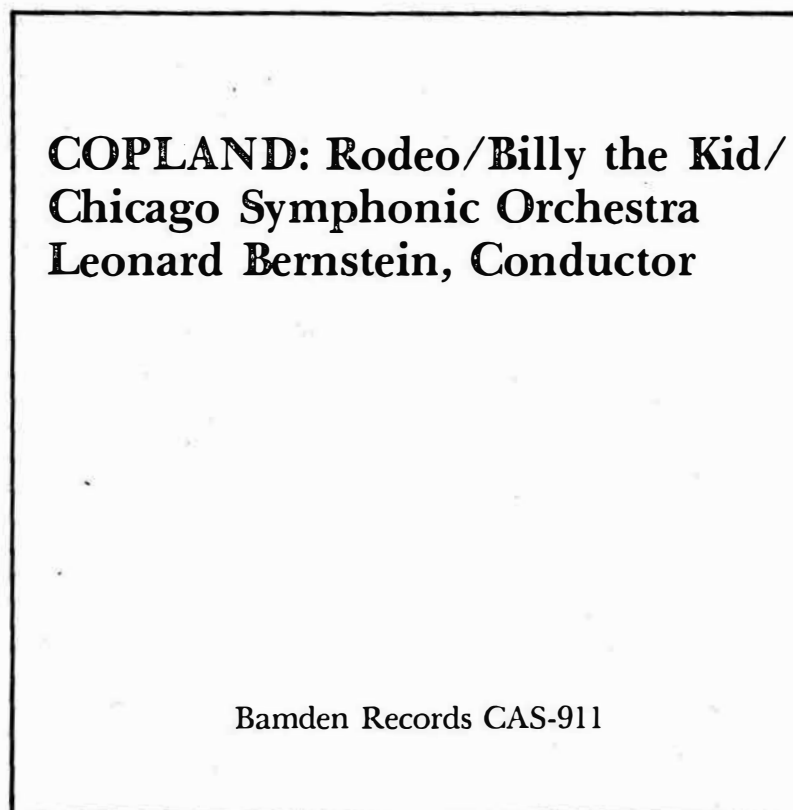

Face of map:

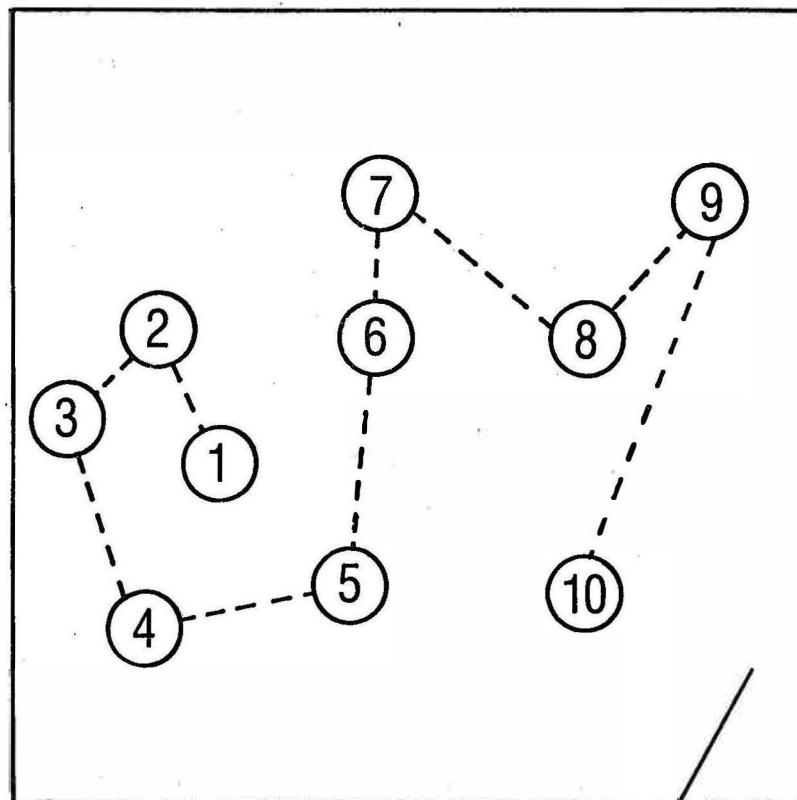

Randall
International Map
of the
WORLD
on Mercator's Projection
copyright by C.S. Randall Co., N.Y.

Notes on format:

Randall has used their standard world map and has overprinted large numbers as a guide to the audio narration. The narrator (un-named) describes living conditions in the various countries of the world through the use of short stories about typical families. Intended for elementary school geography.

There is one 7" monaural 45 rpm record. The map is 33" x 50" and is in color.

Record label:

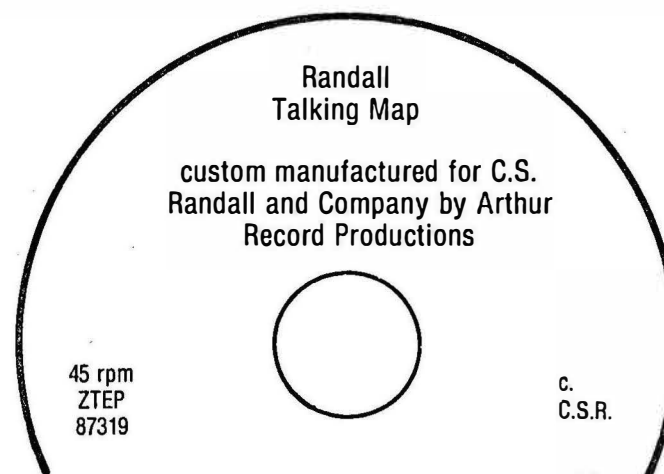

Album cover title:

Record label:

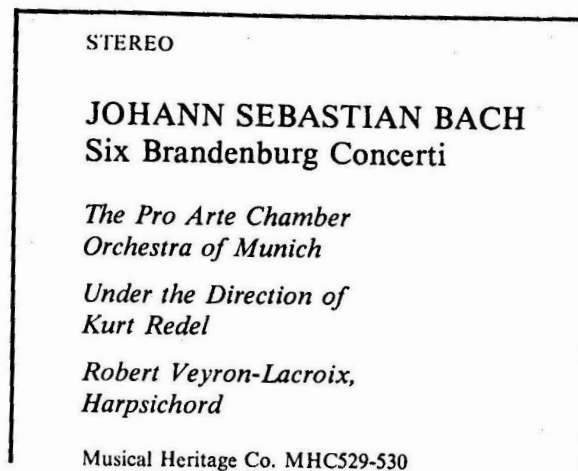

Notes on centerfold of album:

J.S. Bach—Brandenburg Concerto
The Pro Arte Chamber Orchestra of Munich
Robert Veyron-Lacroix, Harpsichord
Kurt Redel, Conductor

(Two 12" records-33 1/3 rpm.
Producer sent date to Library of
Congress as 1963)

Volume 1:

Brandenburg Concerto No. 1 in F Major (BWV 1046)

*1. Allegro 2. Adagio 3. Allegro 4. Menuetto, Trio I, Menuetto, Polacca,
Menuetto, Trio II, Menuetto.*

Reinhold Barchet, violin—Pierre Pierlot, Leonhard Seifert and Wilhelm Grimm, oboes—Kurt Richter and Willi Beck, horns—Karl Kolbinger, bassoon.

Brandenburg Concerto No. 3 in G Major (BWV 1048)

Cadenza by Robert Veyron-Lacroix

1. Allegro 2. Adagio 3. Allegro

Brandenburg Concerto No. 6 in B Flat Major (BWV 1051)

1. Allegro moderato 2. Adagio ma non tanto 3. Allegro

Georg Schmid and Franz Schessl, violas—Irmingild Seemann and Rolf Alexander, violas da gamba, Wilhelm Schneller, violincello—George Hortnagel, contrabass

Volume 2:

Brandenburg Concerto No. 2 in F Major (BWV 1047)

1. Allegro 2. Andante 3. Allegro assai

Reinhold Barchet, violin—Kurt Redel, flute—Pierre Pierlot, oboe—Maurice Andre, trumpet

Brandenburg Concerto No. 4 in G Major (BWV 1049)

1. Allegro 2. Andante 3. Presto

Reinhold Barchet, violin—Kurt Redel and Paul Meisen, flutes

Brandenburg Concerto No. 5 in D Major (BWV 1050)

1. Allegro 2. Affetuoso 3. Allegro

Reinhold Barchet, violin—Kurt Redel, flute—Robert Veyron-Lacroix, harpsichord

Album cover title:

Notes on format:

*GRIEG: Peer Gynt Suites,
Op. 46 and Op. 55*
Bamberg Symphony
Jonel Perlea, Conductor

*BIZET: L'Arlesienne Suites,
No. 1 and No. 2*
Bamberg Symphony
Marcel Courand, Conductor

MOX QUPL 512.410

One 12" 33 1/3 rpm quadraphonic record.

Label on the record gives the same information as the reverse side of the album cover.

This record was originally issued in 1959 and reissued in quadraphonic sound in 1973.

Reverse side of album cover:

GRIEG

Peer Gynt Suite, Op. 46 and Op. 55

Morning Mood

The Death of Aase

Anitra's Dance

In the Hall of the Mountain King

Bamberg Symphony

Jonel Perlea, Conductor

BIZET

L'Arlesienne Suites

Suite No. 1:

Prelude

Minuetto No. 1

Adagietto

Carillon

Suite No. 2:

Pastorale

Farandole

Bamberg Symphony

Marcel Courand, Conductor

MOX Quadramox quadraphonic recording
© 1973 by MOX Productions Inc. N.Y.

Cassette binder:

**JAN-
APRIL
1974**

**Living
History
Cassettes**

**LIVING
HISTORY
CASSETTES™**

Universal Encyclopedia/
CRS News Audio
Resource Library

Subject:
David Rockefeller: *Oil Money
and the Arab World* (10 min.)
Walter Frazier: *"Cool Clyde"* (8 min.)
Pres. Nixon: *News Conference of
Feb. 25, pt.1* (8 min.)

**Living
History
Cassettes**

Side
A

No. 3 For Feb 74
Code 02743

Universal Encyclopedia CRS News Audio
Resource Library ©1974 CR System Inc.

Notes on format:

These cassettes form a sort of periodical. Three cassettes are issued each month. Each binder has room for 12 cassettes or 4 months. In the center of the binder is a "Reader's Guide"-like index which cumulates each month and finally for the year. The index is held in by 3 standard loose-leaf rings. A 1-sheet description page accompanies each tape and contains an outline and excerpts from each speaker's remarks.

This "periodical" began production in 1972. The library began its subscription in Jan. 1973 and has kept it current.

Topics covered are of current world-wide interest and include speakers principally from the U.S. and Great Britain but also English-language speeches and interviews with other world leaders. Topics are not all political in nature.

Face of chart:

LITERARY MAP OF INDIANA

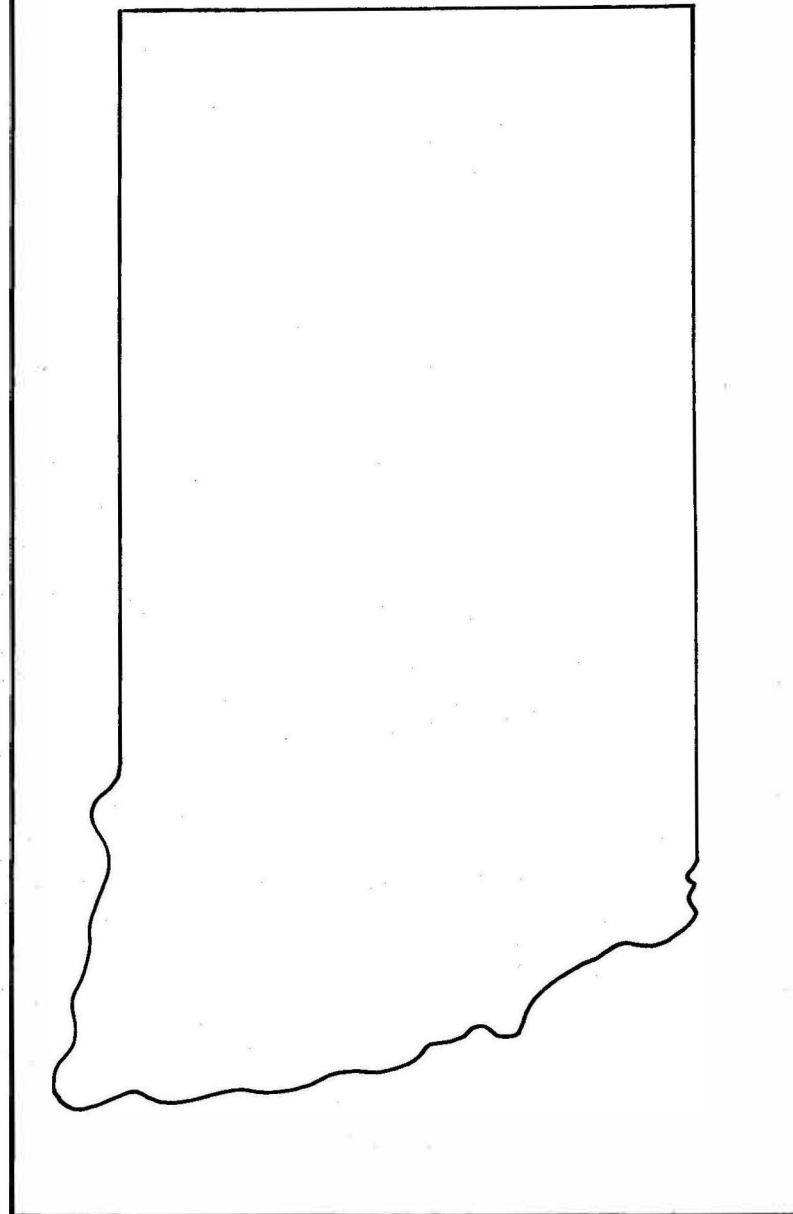

Notes on format:

The map names Indiana authors and their most well-known book. A small picture illustrating a scene from the author's book is placed near the author's birthplace. The margin lists numerous Indiana authors.

The map is 3' x 2' and is in color.

Prepared jointly by:

The Indiana Council of Teachers of English

The Indiana College English Association

Copyright 1956

Committee: Chairman, Seward S. Craig.

Ruth B. Bozell, Arthur Shumaker, William A. Sutton.

The artist: Warren Casey, Ball State Teacher's College.

Face of charts:

EASTERN NORTH AMERICAN WILDFLOWERS 1

Robert's
Aids

Part of a set of 2 wildflower charts

Canada
Mayflower

Purple
Trillium

Canada
Lily

Wild
Strawberry

Jack-in-
the-pulpit

R.R. Roberts Nature Corp. N.Y.

© 1971

EASTERN NORTH AMERICAN WILDFLOWERS 2

Robert's
Aids

Part of a set of 2 wildflower charts

Butter-
and-
eggs

Black-
eyed-
Susan

Pasture
Thistle

One-eye
Daisy

Yellow
Loose
Trife

R.R. Roberts Nature Corp. N.Y.

© 1971

Notes on format:

Both charts are colored.

Size: 60 x 100 cm.

There are numerous flowers illustrated on each poster (those indicated on the left are only examples).

Face of chart:

	BIRD CHART	
	This bird chart together with booklet is available from Peterson's Bird Society: 1234 6th Ave., New York	

Notes on format:

1 colored chart 66 x 100 centimeters.

A 15-page guide accompanies the chart which provides information about each bird on the chart including range, identification, and habits. All birds pictured range from Canada to Mexico.

Guide prepared by Shirley Wright.

Some birds pictured with mates

Face of chart:

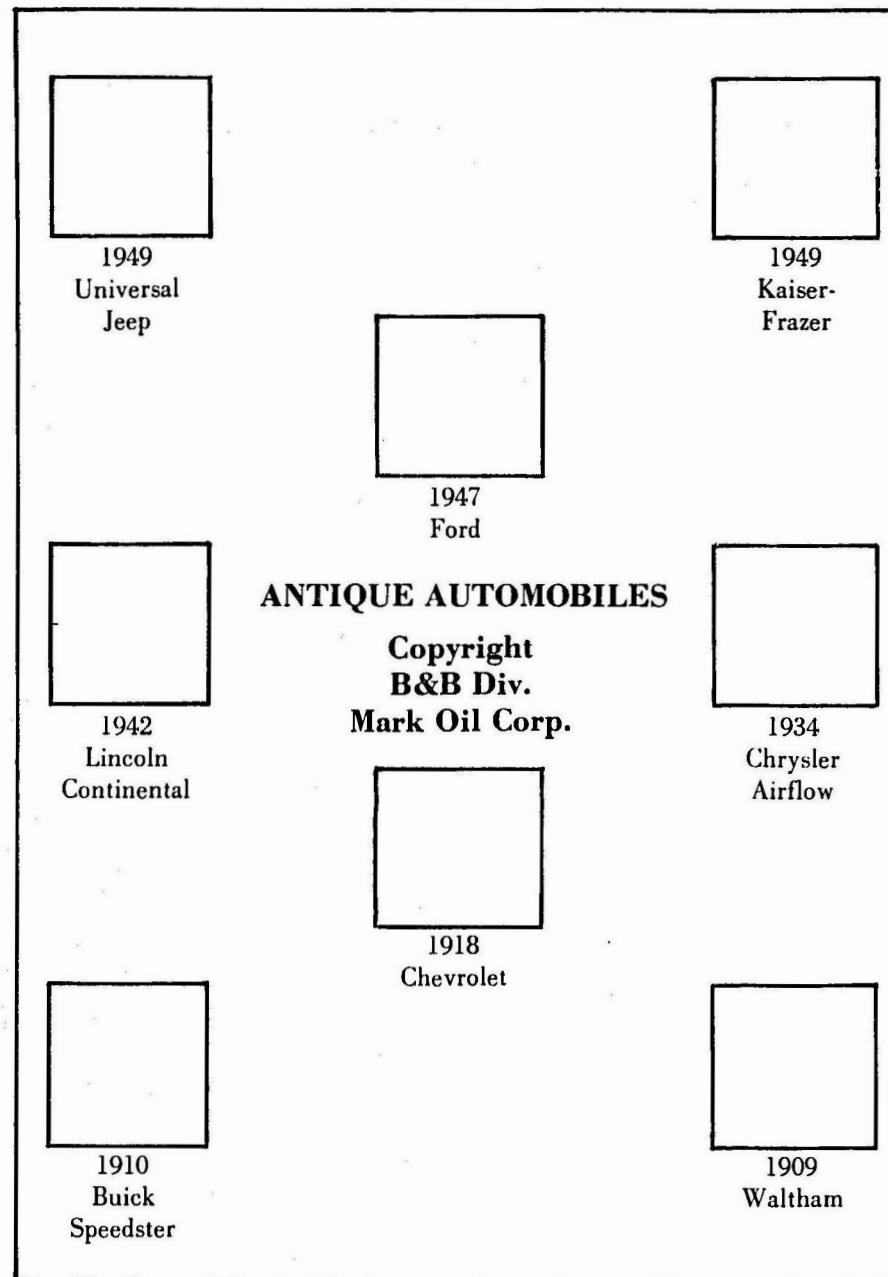

Notes on format:
One colored chart.
25 x 37 inches.
No date on chart.

Box lid:

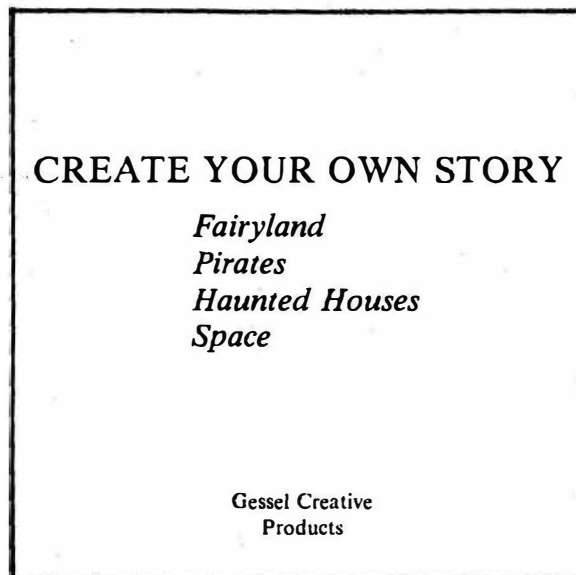

Notes on Format:

The box contains 4 different color backdrops and 75 different stand-up figures. The guide gives 4 different sample stories which can be acted out by children using the figures and the backdrops. The guide gives suggestions and ideas for creating stories in the four subject areas: fairyland, pirates, haunted houses, and space. The purpose of the diarama is to promote language expression in younger elementary school children through storytelling.

Guide title page:

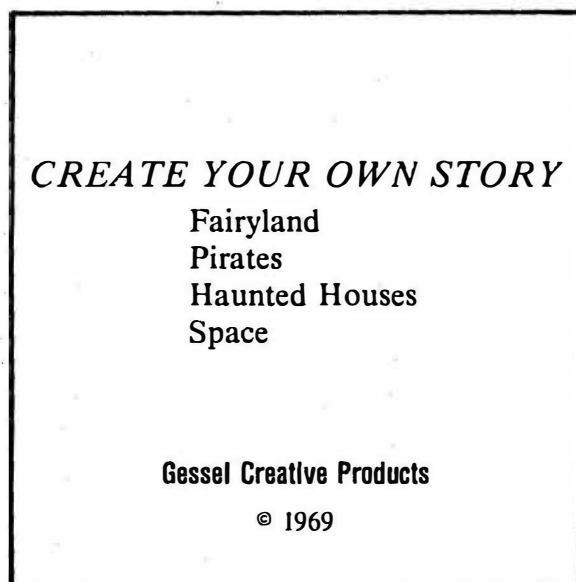

Title on box, filmstrip can, and in leaflet published with the filmstrip:

A JEWISH SABBATH

Title frame on filmstrip:

SABBATH
RELIGION IN LIFE
AAJC

Teacher's guide lists production date as 1968.

Teacher's guide gives the following credits: Producer, Samuel Grand; Research and script, Joseph Gutmann.

Grade level: general: upper elementary—adult

Notes on format:

One 35mm filmstrip in color.

Summary given in Teacher's guide: Describes the development of Sabbath customs in the Jewish home from the earliest sources to contemporary paintings and art forms. Shows the preparations that are made prior to the Sabbath, and home observances through the Havdalah ceremony marking the end of the Sabbath.

Teacher's guide lists AAJC as: Association of American Jewish Congregations.

Set title on box and title repeated on each item.

Notes on format:

ANIMALS IN FABLES
4 Sound Filmstrips
SRE Films

4 color filmstrips, each 36 frames in length. 2 records with 1 side for each filmstrip. Record is 9 minutes long on each side, 33 1/3 rpm., and is 12" in diameter. A study guide (35 pages accompanies the set.

Individual titles and summaries:

The Squirrel and His Friends

Considers whether the squirrel who bakes bread without the help of his lazy friends should give them a taste.

How the Squirrel Saved the Grapes

The squirrel and a friendly bee save the old man's grape harvest for everyone to enjoy.

(Above two titles on the same record)

Adventures of a Little Skunk

Little skunk leaves home and defends himself against a bear, a fox, and two wolves.

Glasses for a Raccoon Child

Poco, a little raccoon who can't see very well, takes a long trip to find a pair of glasses.

(Above two titles on the same record)

Grade level: 1-3

Individual filmstrip title frame:

ANIMALS IN FABLES
THE SQUIRREL AND
HIS FRIENDS
SRE FILMS
1965

Record label:



Title on slipcase:

ER FILMS
Shortstrip

ANIMALS TO LEARN ABOUT

12 subjects:

1. *My Dog Sandy*
2. *Playful Kittens*
3. *Cows on the Farm*
4. *Prince the Riding Horse*
5. *Pigs on the Farm*
6. *The Woolly Sheep*
7. *A Goat Family*
8. *Mother Duck and her Friends*
9. *Chickens on the Farm*
10. *Mother Gray Squirrel*
11. *Mother Rabbit and her Family*
12. *Let's look at Birds*

Notes on format:

Each filmstrip is encased in a plastic sleeve. Accompanying each filmstrip is a card giving brief facts about each picture. Each filmstrip has 14 frames: 12 color pictures, and one questions frame. Each frame is captioned. For preschool children.

Individual filmstrip title frame:

Animals to Learn About

PIGS ON THE FARM

Collaborator: Grace Storm

Produced by:
Educational Resources Films

© MCMLXI by Educational Resources
Films Inc. Copyright and all
rights of reproduction, including
by television, reserved

Set title on box and title repeated
on each item:

FAMILIES IN CENTRAL AMERICA

4 filmstrips with cassettes

Smith Educational Corp.

Sample individual filmstrip title
frames:

SEC Presents

**A BANANA-GROWING FAMILY
OF HONDURAS**

*Script and Narration by
Richard B. Lee*

Photography by
Richard B. Lee and Irven De Vore

Smith Educational Corporation
New York

copyright 1968, 1971

Notes on format:

4 color filmstrips, each of varying length. 4
cassettes, each of varying length. 4 teacher's
guides—32 pages each.

Individual titles:

A Banana-Growing Family of Honduras
57 frames, 6 minutes

A Village Family of Guatemala
66 frames, 8 minutes

A Modern City Family of Mexico
60 frames, 9 minutes

A Sisal-Weaving Family of Yucatan
61 frames, 7 minutes

Summary of the series: Full-color photography
presents an up-to-date survey of life in various
Latin American countries. Students observe
life-styles of families living in different regions
whose national and economic backgrounds
vary considerably.

Available in a Spanish language version:
Familias de la America Central.

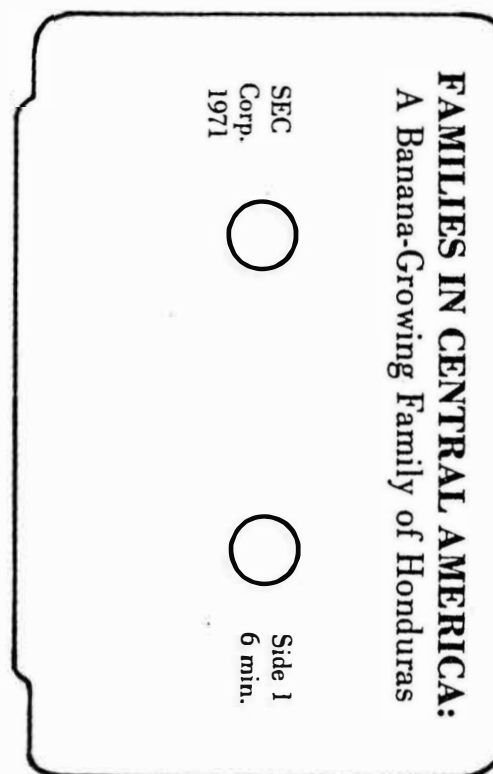

Title on box, teacher's guide,
record labels, and filmstrip cans:

Notes on format

Hoffman's What is Poetry?

The box contains 10 filmstrips, 10 records, teacher's guide, and 1 set of duplicating masters. The titles of the filmstrips are:

First frame on each filmstrip:

***HOFFMAN'S
WHAT IS POETRY?***

A series of filmstrips
produced by
HOFFMAN RECORDS, INC.

copyright, 1970

What is a Poem?

Carl Sandburg Looks at Poetry
Rhythm is the Heart of the Matter
Rhyme Time

The Color and Texture of a Poem
Building a Poem—Stanza by Stanza
About Ballads

Nonsense Makes Sense

Metaphors and Similes—Imagery!
Who's a Poet?

Sample filmstrip title frame:

**CARL SANDBURG
LOOKS AT POETRY**

© 1970 Hoffman Records

Each color filmstrip is numbered HFS101—HFS110. The 10 records are each 12", 33 1/3 rpm, and may be played on either stereo or monaural phonographs. There are two soundtracks for each filmstrip—one side of the record has automatic advance signals—the other side has audible tones for manual frame advance.

Sample frame following title:

Narrated by Claire Bloom
with the voice of Carl Sandburg

The teacher's guide is 50 pages in length.

There are 30 tear-out duplicating masters bound into a booklet.

The manufacturer's number on the box and the teacher's guide is: HFC501

Sample end frame:

Hoffman's What is Poetry?

Produced by
Hoffman Records, Inc.

Design & script by
Mazin-Wykoff Company, Inc.

Continuity by
Shirley Joel
Lucille Schulberg

Each filmstrip is 60 frames in length. Each record is approximately 9 min. for each side.

Title on filmstrip can:



Title frames on filmstrip:

AUTOMOBILES
*Great Contributors
to Smog*

Adviser:
John R. Eales

Special Consultant:
John S. Urlaub

Coordinator:
Ruth S. Hartman

Made by:
Roberts Productions

for:
The New York Air
Resources Board

in association with:
The New York Dept.
of Public Health
1965

Notes on format:

This black and white filmstrip of 155 frames comes with a 12" record—20 minutes in length and a discussion guide manual (30 pages).

Summary:

Explains what smog is, what causes it, what the automobile driver can do to lessen it, and what New York law requires regarding smog control devices on automobiles.

Title on the box:

LOVE IS EVERYWHERE
A PARTICIPATION FILMSTRIP
Audio Graphics

Title frame and ending frames:

LOVE IS EVERYWHERE

Distributed by:

AUDIO GRAPHICS

**Materials originally
prepared by:**

Graded Instruction, Inc.

Notes on format:

One 35mm filmstrip—67 frames. 1 phonodisc with sound on one side—7" 33 1/3 rpm, 5 minutes in length. One leader's guide. Six 2 x 2 Kodak slidemounts and one sheet of Marvalon—the purpose of which is to let children draw on the film and illustrate the song: Love is Everywhere.

Summary:

The folk song: "Love is Everywhere," sung and played by Ray Repp, as background music for: series of pictures which help children see how they can become sensitive to and respond to the needs of others. Designed to be used in Sunday Schools or in religious training.

Grade level:

Upper elementary.

Title on filmstrip can:

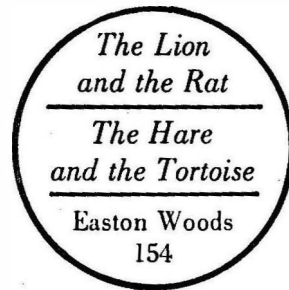

End frame of second title:

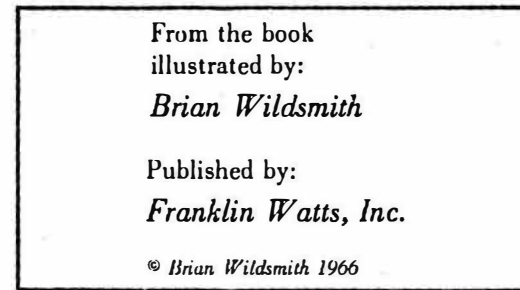

First title frame on filmstrip:

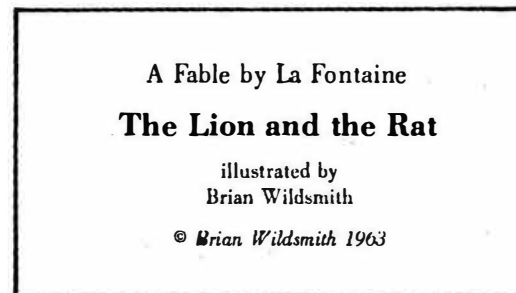

Final end frame:

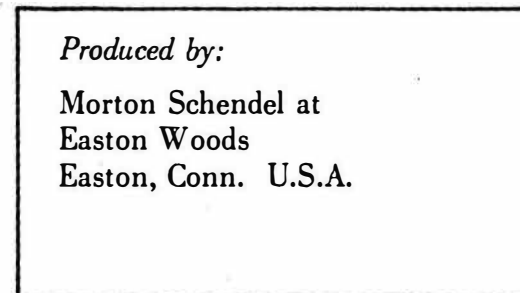

End frame of first title:

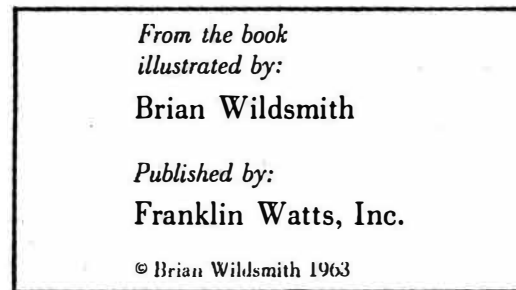

Record label:

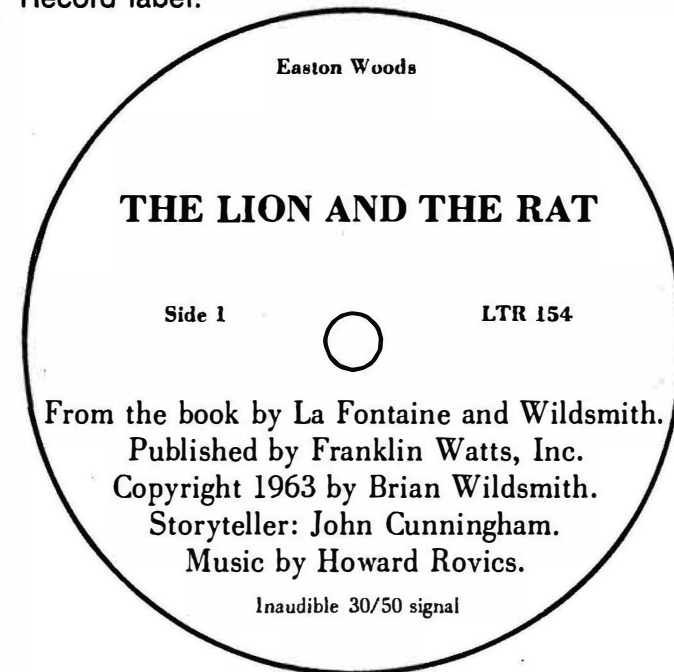

Second title frame on filmstrip:

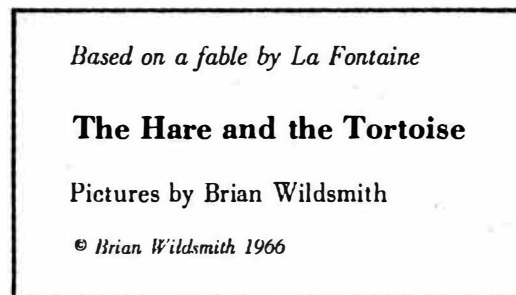

Notes on format:

Both stories are on the same color filmstrip. The 6" record is 33 1/3 rpm and uses the same storyteller and composer for each story.

Box title:

Notes on format:

Box contains 150 picture-word cards. Pictures are black outlines on buff cards.

Size: 3 x 2 inches.

PICTURE-WORD CARDS

Designed by
Mark A. Hallett

Marrard Publishing
Company, Champaign,
Illinois

Sample card:

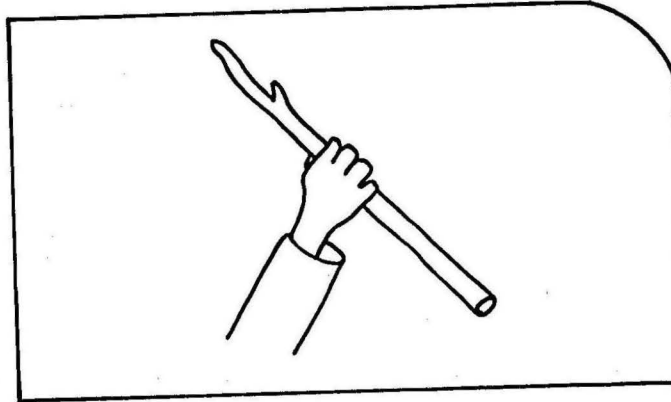

Reverse of card:

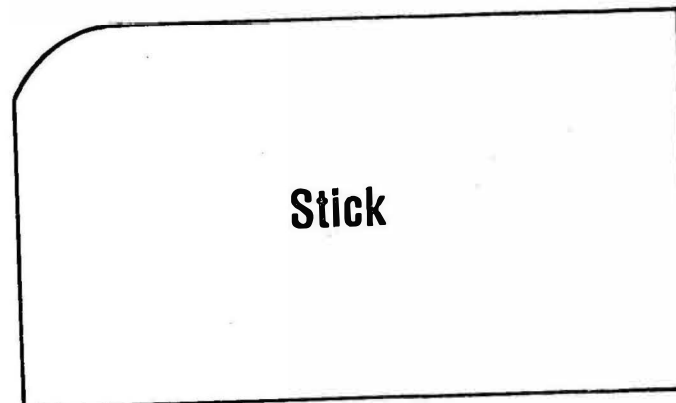

Box title:

THE NEW I CAN READ SET

Complete word, phrase, and
picture card equipment for
the Pre-Primer and Primer
Programs: The New Basic
Readers Curriculum
Foundation Series

Stott, Moresman & Co.

Notes inside box lid:

The New I Can Read Set provides enough word and phrase cards to set up in the pocket chart all the developmental and practice material suggested in the Guidebooks for the Pre-Primer and Primer levels of The New Basic Readers (1974 ed.)

Notes on format:

The box includes 158 word cards and 85 phrase cards; a stand-up small pocket chart in which the cards may be arranged and positioned according to the teacher's needs. Each card is 3 x 6 inches and has black letters printed on a buff background. Some word cards have black outline drawings.

Tutorcard machine:

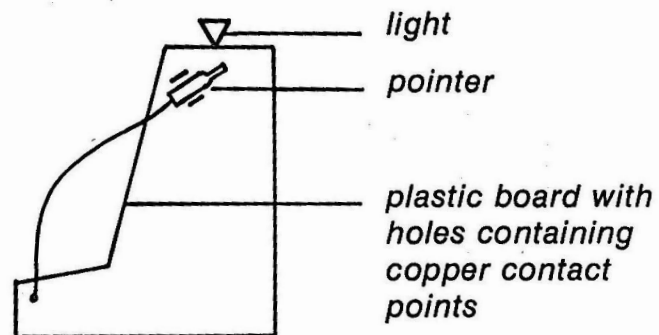

Card box title:

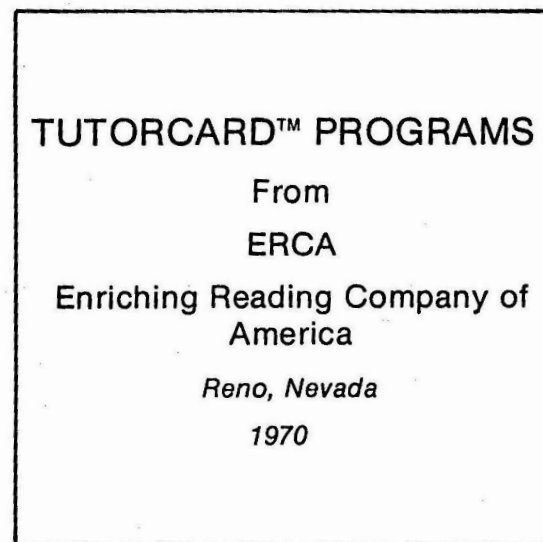

Sample tutorcard:

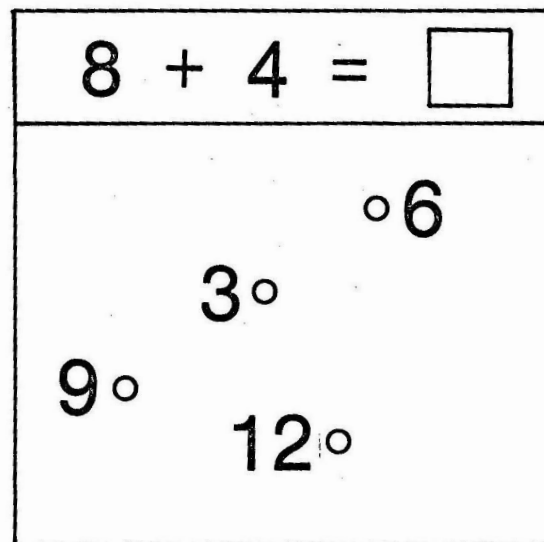

Notes on format:

The box contains 12 sets of brightly colored flash cards designed to be used on the tutorcard machine. The child is to set a card on the machine, select an answer, and push the pointer through the hole beside the answer he thinks is correct. If the right answer has been chosen, the light on the top of the machine lights up and a buzzer sounds. Each set contains 54 cards.

Titles of card sets:

1. Kindergarten and First Grade Vocabulary
2. Pre-school and Kindergarten Reading Readiness
3. Equivalent Coins
4. Matching
5. First Grade Consonant Sounds
6. Kindergarten and First Grade Common Terms
7. Alphabet Recognition and Sequencing
8. Vowels
9. First Grade Science
10. Second Grade Science
11. First Grade and Second Grade Social Science
12. First Grade and Second Grade Mathematics

Game box top:

GO FISHING

A Consonant Sound Game

1st Series: Consonant Sounds

*Published by the
Remedial Education Center
Philadelphia, Pa.*

Notes on format:

60 colored playing cards
plus 1 directions card.

Rule directions card:

The Go Fishing Sound Game

A game to teach children
the consonant sounds

RULES

Devised by *Marion Kingsbury*
Drawings by *Prentiss Taylor*
© 1941 by *Marion Kingsbury*
© 1968 by *Marion Kingsbury*

r

R

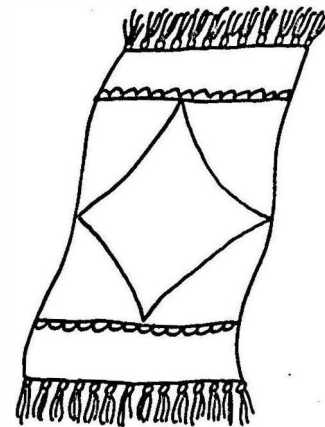

rug

Loose-leaf style game cover:

OLD/YOUNG
The Generation Gap

Serie Educational Games, Inc.

by
Erling O. Schild, Ph.D.
and
Sarane S. Boocock, Ph.D.

Game components:

1 instructor's manual
20 issue cards
1 pad of scoring sheets
1 molded plastic playing board

Summary:

The objective of this simulation game for 4-6 players is to teach ways of turning conflict between teenagers and their parents into something gentler and more effective—understanding.

Title page of instructor's manual:

OLD/YOUNG
The Generation Gap

Instructor's Manual

Erling O. Schild, Ph.D.
Hebrew University,
Jerusalem

and
Sarane S. Boocock, Ph.D.
University of Southern
California

*Published by: Serie Educational
Games, Inc. 1973*

Cover (Title page) of Leader's Handbook:

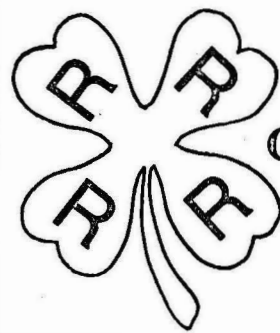

GAME OF DEMOCRACY

*Created by James S. Coleman
Professor of Social Relations
Johns Hopkins University*

Published by the National
4-R Club Foundation

*Copyright 1966
by James S. Coleman*

This set of games is one of a series of games (simulations) developed by the Johns Hopkins University School of Social Relations to teach how democracy works.

Notes on format:

This kit contains the materials for three games but also suggestions for five other advanced versions of the three basic games.

Basic game titles:

1. Legislative Session
2. Citizens' Action Meeting
3. Representative Democracy

Advanced version titles:

1. A Legislator's own Convictions
2. The Power of the Floor Leader in a Legislature
3. Passage of Legislative Program
4. Committee Structure in the Legislature
5. Taxation and Public Expenditure

From the leader's handbook:

GAMES MATERIALS IN EACH KIT

- 1 leader's handbook (contains the rules for the 5 advanced versions of the 3 basic games)
- 52 Constituency cards (white)
- 20 age, sex, and marital status cards (tan)
- 20 occupation, income, and race cards (buff)
- 66 regional cards: 11 cards for each of 6 regions (salmon, cherry, green, blue, canary, and gold)
- 8 issue cards (gray)
- 2 rules for game I, with chairman's check list on back page
- 2 rules for game II, with chairman's check lists on back page for Games II and III
- 2 rules for game III
- 44 legislator's work sheets, with secretary's roll call form on back
- 44 citizen's work sheets, with secretary's roll call form on back

Work sheets may be reused; mark them with pencils that may be erased easily. Additional sets may be ordered from the National 4-R Club Foundation.

Teacher's Manual title page:

THE ENVIRONMENT OF MAN

A Classroom Ecology Kit

Presented by Super-Cola USA
and the bottlers of
Super-Cola

© 1970 by the Super-Cola Co.

Notes on format:

There are two games in this kit: Rescue in Space and Make Your Own World. Each game has various playing materials: cards, scoring pads, game board, etc.

Foreword from teacher's manual: The Environment of Man was developed by the Super-Cola Co. in response to a need of American society and American educators. This program has three purposes: First, to help children become more aware of their environment; Second, to help children appreciate their interdependence with their environment; And, third, to help children realize that, as human beings, they can make decisions which will affect their environment for better or worse.

Each simulation exercise and the kit as a whole were developed with the help of Dr. Frank B. Golley, Executive Director of the Institute of Ecology, University of Georgia. We are indebted to him for shaping the original concept and supervising its execution, and to educators in New York and Georgia who enabled us to test the various exercises in their classrooms and who offered constructive suggestions and encouragement.

Simulation game: Rescue in Space. Players (8-60) are on a mission to Mars in two spaceships. One of the spaceships is disabled upon landing. Four groups of players are put in charge of air, food, water, and living space. The object is to plan the efficient use of materials and return home.

Simulation game: Make Your Own World. The game is played on an illustrated board which simulates a geographical area containing forests, farms, rivers, and urban areas. Each player is assigned a role. It may be a human role, such as a store owner or a farmer; it may be an animal role, such as a fish or a deer; or it may be a basic resource role, such as air or soil. The players are presented with a series of proposals about adding various man-made features to the board, such as an airport and a shopping center. The players discuss the possible consequences from the viewpoint of the roles they are playing.

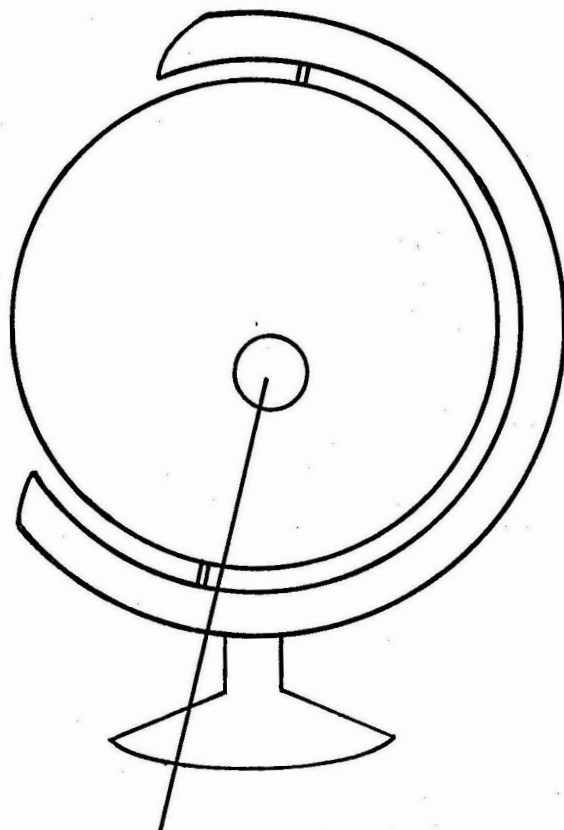

Relief 12 in. diameter globe

WORLD OCEAN

Natural scale 1: 41,849,600

Relief Globes

© Wiley Corporation

Made in the USA

Notes on format:

Continents and ocean floor are in relief and in color.

The two monaural 7" records describe the makeup of land and ocean areas.

A 13pp. booklet explains the various parts of the globe and geographical features of the earth. It was copyrighted in 1970 and is entitled: The Story of the WORLD OCEAN Globe.

Record labels:

The Land of Mr. Earth

©1964

High Fidelity Recording

Relief Globes Inc.

33 1/3
rpm

GO 124-1
ZCTV 97167



The Oceans of Mr. Earth

©1965

High Fidelity Recording

Relief Globes, Inc.

33 1/3
rpm

GO 124-2
ZCTV 104190



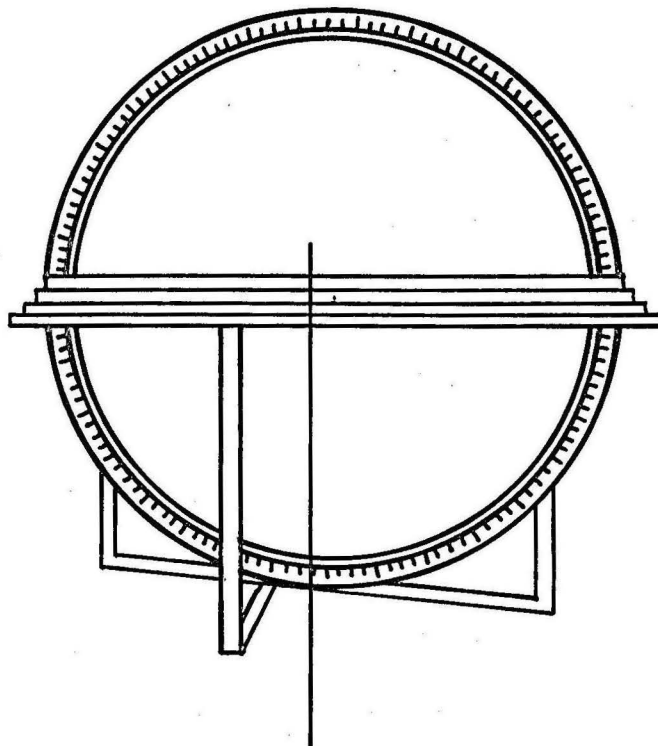

**BROCK'S
16"-Celestial Globe**

Star Magnitudes

☆ ☆ ○ ☆ .
1 2 3 4 5 or less



Milky Way

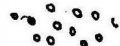

Nebula or Cluster

**Brock May and Globe Corp.,
Columbus, Ohio**

Notes on format:

Publisher's catalog states:

- *Shows selected stars of celestial sphere
- *Stars in white on deep blue background
- *Basic requirement in study of astronomy
- *User imagines he is on inside, looking out
- *When correctly adjusted, the celestial

Globe shows stars as they appear at any hour during any night of the year, and from any point on the globe.

The globe does not list a catalog number but it's original order number when purchased in 1972 1645c.

Mounting: table stand.

A 16-page manual describes the uses of the globe and the various constellations shown.

Notes on format:

Publisher's catalog lists no date of production. Date is not on the globe. Globe was purchased in 1969.

Publisher's catalog lists mounting as: horizon ring cradle mounting.

Smooth surface—printed in 4 colors illuminated.

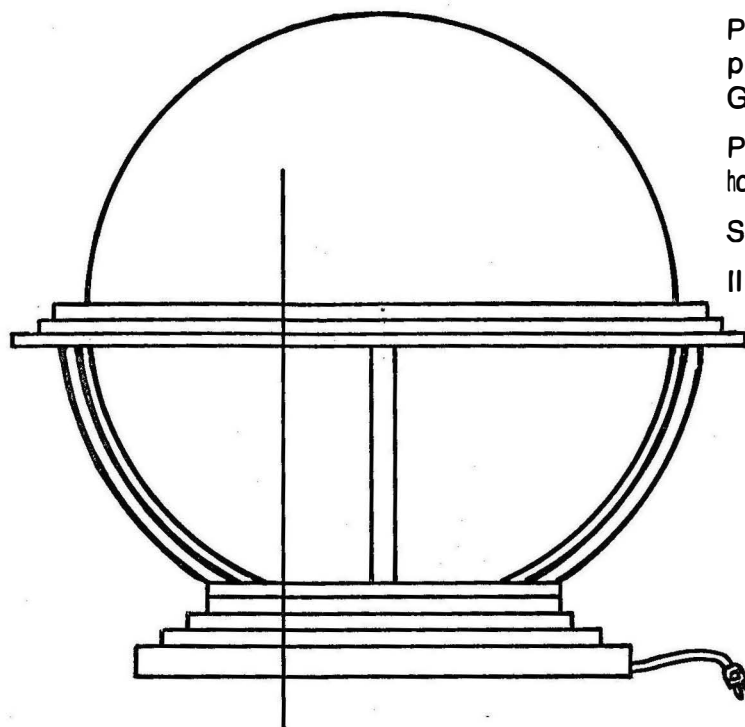

16-inch
Physical-Political
Terrestrial Globe

BRAM'S
(Since 1876)

C1264

Natural Scale 1 = 31,680,000
one inch = 500 Statute Miles

*Copyright by
The Mark F. Bram Co.
St. Louis, Mo.*

Globe box:

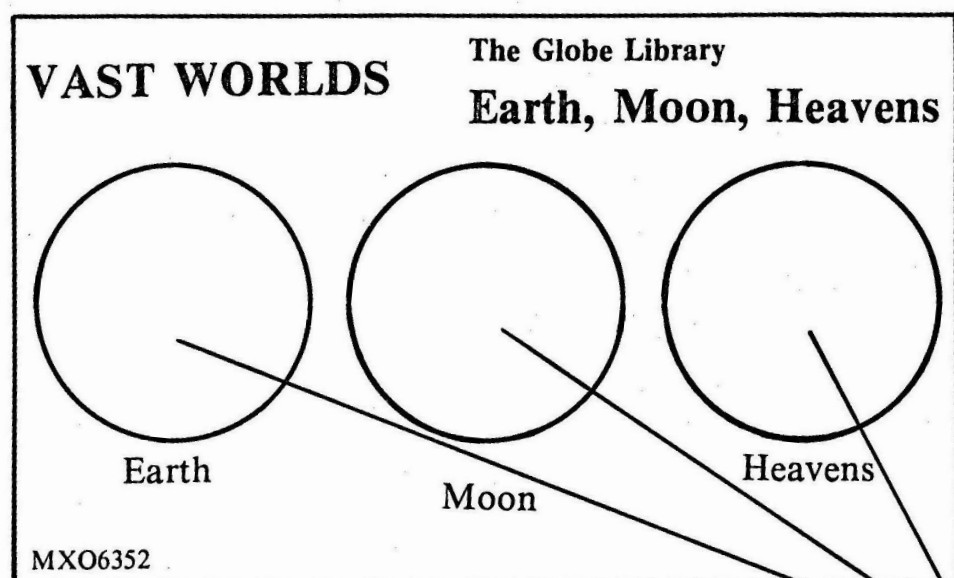

Sample printing on globe:



holes showing
globes inside

Catalog notes:

A complete library of globes for young students including an earth globe, moon globe, and a celestial globe. Each is six inches in diameter, and each has its own handbook of uses. Earth globe is in seven colors. Moon globe shows Apollo landing sites, Earth side, and "far" side. Celestial globe is an authentic guide to studying the stars. All are detailed, accurate, up-to-date and in relief.

Each globe has its own plastic cradle stand.

Box label:

A Multimedia
Unit For:
Economics
Home Economics
Consumer Education

WISE SPENDING

*Wolcott Forward
A Division of
McTaw-Hill
Inc.*

Title page of teaching guide:

WISE SPENDING

Published in cooperation with
the Better Business Bureau of
Metropolitan New York

General Editor
Arthur Startz

Consultants
Margaret Reiss
Home Economics Department

Daniel C. Smith
Social Studies Department

Woodlands High School
Greenburgh Central Dist. 7
New York

Wolcott Forward
A Division of
McTaw-Hill
Inc.

©1971

Notes on format:

The kit is designed to help students understand that spending money requires information and decision-making skills; responsible consumers can get more for their money than passive ones; and knowing who you are and what you want is necessary in smart spending.

The kit contains:

- 2 color filmstrips
- 1 record
- 30 garment hangtags
- 10 role playing scripts
- 100 problem cards
- 26 reading books (23pp)
- 1 teacher's guide (100pp)

Filmstrip cans:

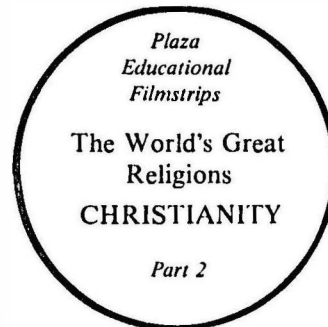
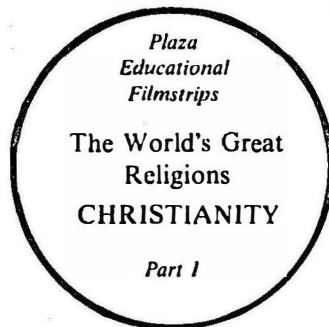

Cassette label:

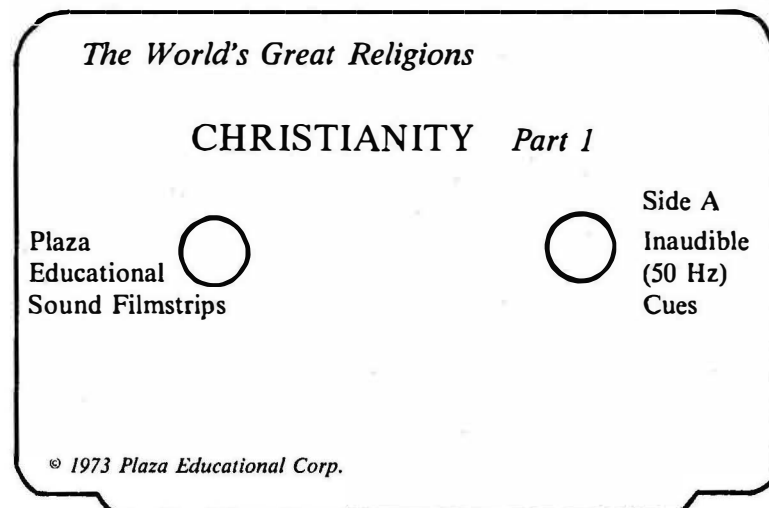

Record label:

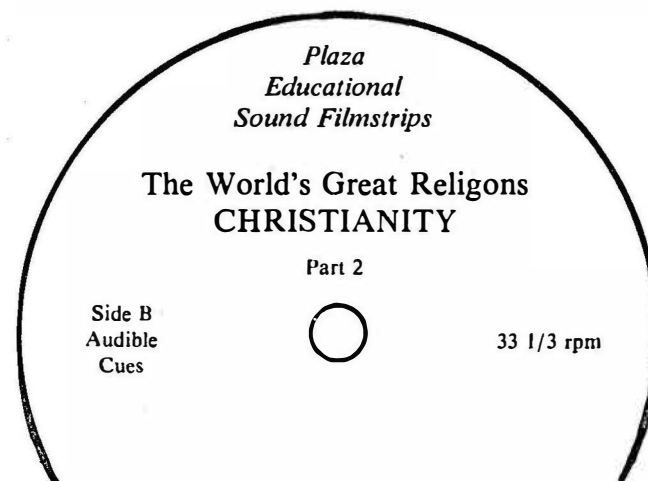

(side A is the same sound track with
inaudible cues)

Notes:

These two color filmstrips were purchased with two cassettes and two records. Both soundtracks are identical in every way except for the format. Both formats were purchased to take advantage of various pieces of equipment. The user may choose the cassette version or record version depending on which piece of equipment is handy. The set comes with 20 copies of a reprint from Plaza magazine from their series: "The World's Great Religions." The reprint is in color, 15 pages in length, and dated 13 June 1955.

Cover of reprint:

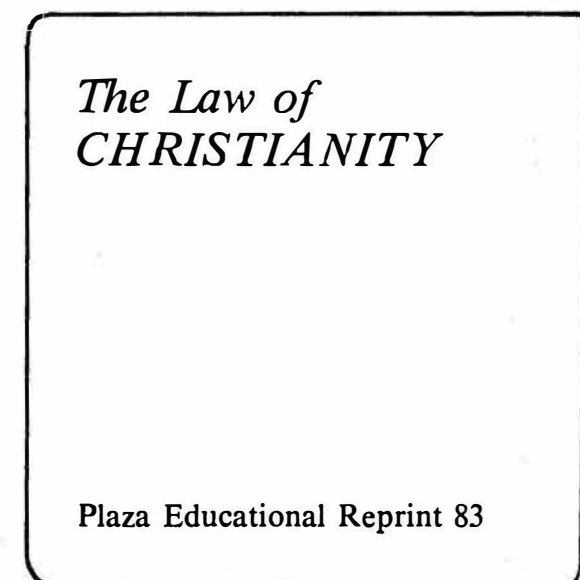

Label on box:

**U.S.
Geographical
Society**

**Around
The World
Program**

**Nelson Doubleday
Inc.**

Notes on format:

A small doll is included which is dressed in a Canadian costume and is 4 3/4" tall. Sticker on apron says: Made in Italy.

The booklet describes the land, industry, history, and people of Canada. It has colored picture-stickers in the center which may be detached and pasted on various pages throughout the text. 64pp.

The doll and booklet are housed in a book-shaped box 8 1/2" tall. The kit is one of many produced by U.S. Geographical Society describing the various countries of the world.

Booklet title page:

CANADA

Around the World Program

Verso of title page:

**Prepared with the co-
operation of the U.S.
Geographical Society**

**© 1968 by Nelson
Doubleday, Inc. Published
by Nelson Doubleday, Inc.
and Odhams Books Ltd.
Printed in the U.S.**

Kit box top:

HOW TALU THE ELEPHANT GOT HIS TUSK BACK

A West African Folk Tale

Rainbow Education Corp. MK1900

Kit contents:

- 1 two-sided tape
- 4 two-sided, colored, study prints
13x18 in.:
 - Side 1: the story illustrations
 - Side 2: pictures of West Africa
- 4 puppets representing the story characters and an African narrator:
 - 1 snake
 - 1 leopard
 - 1 elephant
 - 1 African narrator
- 1 teacher's manual which includes the scripts of the folktale and the factual narration.

Teacher's manual title page:

Teacher's Manual

HOW TALU THE ELEPHANT GOT HIS TUSK BACK A West African Folktale

Rainbow Education Corp.
© 1973

Cassette—Side 1:

Use with study prints
SP1900 1-4

Cassette
MK1900 -ITC

HOW TALU THE ELEPHANT GOT HIS TUSK BACK



Side one
Time:
10:00

A West African Folktale

Rainbow Ed. Corp.
© 1973

Cassette
MK1900BT

(Reverse) LIFE IN WEST AFRICA

Side two
Time:
8:00

Use with study prints
SP1900 1-4

Rainbow Ed. Corp.
© 1973

Box title; record title; filmstrip title:

JOHN PHILLIP SOUSA

by
Robert Norman and
Stephen Wright

GREAT COMPOSERS SERIES

Randhouer Co.
© 1972

Grade level: 5-12

Notes on format:

Set contains 1 record, 2 filmstrips, teacher's guide, 2 study prints. All items are in a box with the exception of one large study print.

Description of components:

filmstrips: Two full color filmstrips containing more than 75 photographs of concert halls, homes, memorabilia, portraits, contemporary prints, printings, and etchings associated with the composer's life.

record: A 30 minute narration presented in two segments on a 12" LP record 33 1/3 rpm.

small study print: Full-color 9"x12" picture of Sousa mounted on cardboard

large study print: Full-color 16" x 20" study print picture of Sousa mounted on heavy cardboard.

teacher's guide: Contains extensive teaching suggestions and a time-flow chart of events contemporary with the composer's life. 56 pages.

Box title: None
Grade level: None specified.

Notes on format:

Cardboard box contains four small jars containing rock samples of four types of rocks: volcanic, plutonic, metamorphic, and sedimentary.

100 2x2 in. color slides show the various formations from which the rocks were taken.

One booklet describes the various types of rocks and how they were formed.

One sheet of typed directions gives guidance to the discussion leader.

This box of materials was donated to the library by a local geologist, David Kessel, who took the slides and collected the samples. The librarian prepared the sheet of directions and found the booklet to include in the box. Prepared in 1965.

Box title; art print ring-binder title; and minibook cover title:

SONGS FROM MOTHER GOOSE

Edited by:

Beth Dure and Lucille Ladd

Narrated and sung by:

Marni Brown

Orchestrated by:

Edward B. Lorey

Designed and illustrated by:

Paul Smith

Little Jack Horner; Hot Cross Buns; Simple Simon; Hey Diddle Diddle; Jack Sprat; Old Mother Hubbard; Baa Baa Black Sheep; Little Bo Peep.

WAYMAR AND SONS, INC.

Grade level: Primary grades.

Notes on format:

Set contains: 8 art study prints in a 4-ring binder (one print per rhyme); 8 verse cards; 15 sentence strips; 125 vocabulary cards; teaching suggestions on each art study print; 2 filmstrips; 15 minibooks; 1 cassette.

Packaging: Set comes in large colorful cardboard box with study print binder separate.

No date on any of the materials or box. Listed as NEW in the 1973-1974 Waymar catalog.

Description of components:

Verse cards: verses to match the art study prints on 22" x 29" board in large type, packaged in pocket of ring binder.

Sentence strips: perforated verse cards that can be separated into phrase and sentence strips.

Vocabulary cards: 125 cards of key words selected from the verses, 4"x6".

Minibooks: Reductions of the art study prints and verse cards in a 4" x 6" softcover minibook containing all 8 rhymes. Color. No paging.

Filmstrips: Full-color filmstrips; each with 40 frames and 4 rhymes on each strip.

Cassette: 4 songs on each side of the cassette which correlate to the filmstrips.

Teaching suggestions: Suggestions for using the materials in language arts, phonics mathematics, and social science activities are included on the back of each art study print

Art study prints: Giant full-color nursery rhyme art prints, 22"x29", on quality board with glare proof finish, packaged in ring binder.

Title on box:

**MATH PRINCIPLES
LEARNING MODULE**

Winger Co.

Title on most individual items:

Math Principles

Notes on format:

Set contains 12 filmstrips with 6 cassettes; 12 beginning math concepts cassettes with response card lessons with wax markers; 125 small study prints with 7 index cards; 30 number lines; 2 board games; 1 floor game; 40 flash cards; 4 geometric shape inlay forms with 15 insets; 30 student booklets; teacher's manual. All in large cardboard box.

Listed in the 1970 sales catalog from Winger but not in the 1969 catalog.

Grade level: Primary grades

Description of components:

Filmstrips: Group 1 (6 filmstrips, 3 cassettes): Cardinal numbers 1, 2, and 3; Cardinal numbers 4, 5, 6, and 7; Cardinal numbers 8, 9, 0, and 10; Comparing numbers; Joining and separating sets; Geometric shapes.

Group 2 (6 filmstrips, 3 cassettes): Addition combinations and sentences; Subtraction combinations and sentences; Place value: ones, tens, and hundreds; Addition facts through 18; Subtraction facts through 18; Fractions.

(each filmstrip approximately 80 frames, colored, 8 1/2 min.)

Cassette/response card lessons: 24 individualized lessons for reinforcement of basic math concepts. 24 lessons on 12 cassettes with 12 cards and different color wax markers. Each cassette 30 min.

Mini-Prints (small study prints): 125 colorful 3" x 4" cards with 7 index cards.

Number lines: 30 number lines, each 20" x 4".

Board games: 1 playing board 20" x 20" with one game on each side. Titles: Match it (with 40 playing cards); Make and take (with 60 playing cards).

Floor game: one 43" x 90" colorful "carpet" covered with geometric shapes.

Flash cards: 40 2-sided flash cards in color containing addition and subtraction facts.

Geometric shapes: 4 plastic molded inlay forms with 15 geometric shaped plastic insets.

Student booklets: 30 colorful booklets 30p.

Teacher's manual: Complete instructions and suggestions for correlation with several basic math textbook series.

Computer card box and label:

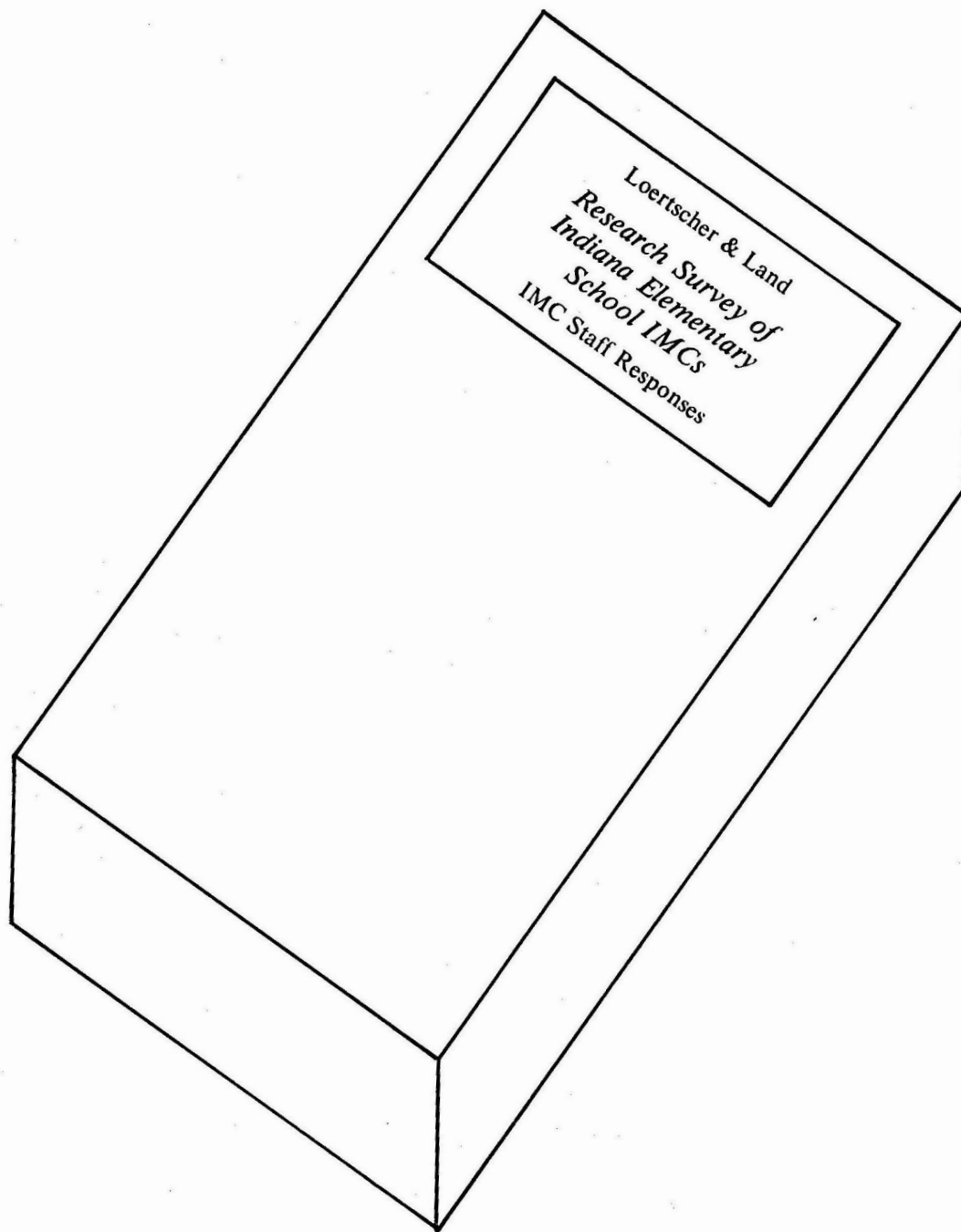

Notes on format:

The data in punched card form comes from 197 schools in Indiana collected in October of 1973 by questionnaire. David V. Loertscher, Purdue University, and Phyllis Land, Indiana State Department of Public Instruction, conducted the study and collected the data. The card punching was done in Indianapolis by the State Dept. in March of 1974. Each school's data occupies a five card set. Thus, there are 197 sets of 5 or 985 cards.

Computer tape reel:

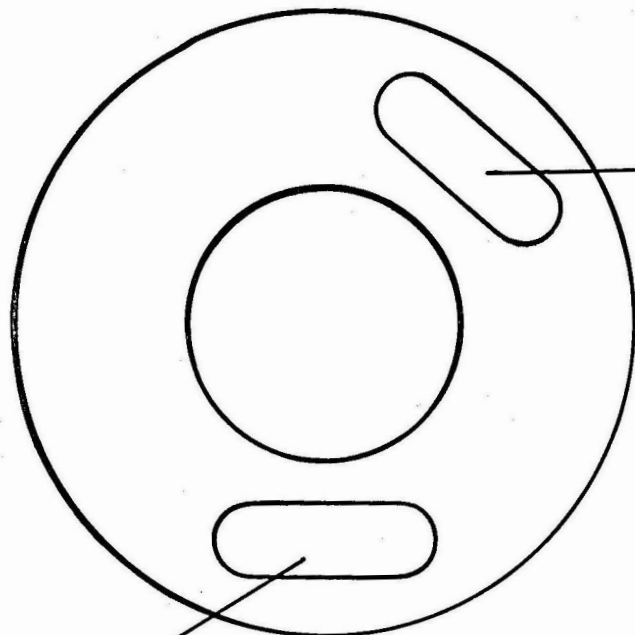

Storage Slot: No. 317
Write Protect Key: RFZ

Northwestern University Computing Center
SPSS Data Package Version 5.5
No. 7437932

Notes on format:

This 10½" reel of ½" magnetic computer tape (2400' in length) was obtained from Northwestern just after the version became available in 1973. The tape contains approximately 2500 logical records. SPSS is an abbreviation for Statistical Package for the Social Sciences.

Title side of map:

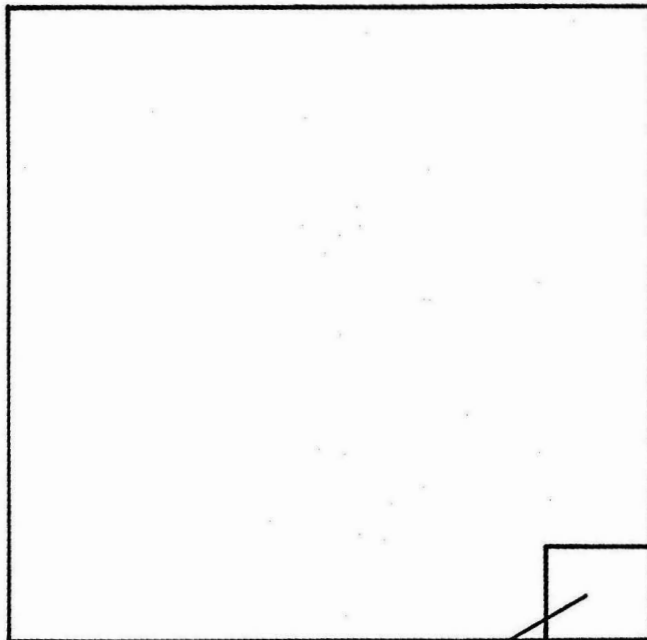

*Regional Geographic
map of*

THE HEAVENS

with
Monthly Star Charts
for
Both Hemispheres
© 1970

Notes on format:

The title side of the map is printed in blue ink. The reverse side is multi-colored. The title side shows a star chart for every month of the year and for both hemispheres. The reverse side shows the northern sky and the southern sky and outlines various constellations. 10 insets around the border enlarge the constellations.

The map is 3' x 2' with a 1" border.

Reverse side of map:

THE HEAVENS

Compiled and Drawn by Edward
Bolinsky of the Regional
Geographic Co. Washington,
1970.

Face of map:

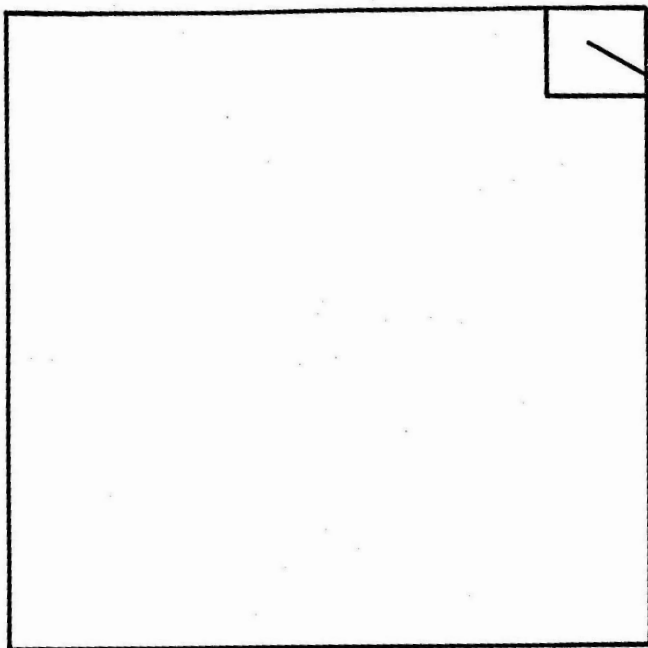

ANTARCTICA
Atlas Plate: Feb. 1963

Compiled and Drawn in the
Cartographic

Division of the U.S.
Geographical Society for U.S.
Geographical Magazine.

Melvin G. Ross, *Editor*
James M. Rostern, *chief*
cartographer

Azimuthal Equidistant
Projection

Scale: 1:9,920,800 or 155 miles to
the inch.

Notes on format:

A very informative color map showing current and
past bases, explorers' routes, elevations, etc.

Size: 67 x 75 centimeters.

The map has been laminated and mounted on stiff
cardboard for permanence. There is no border.

Map face:

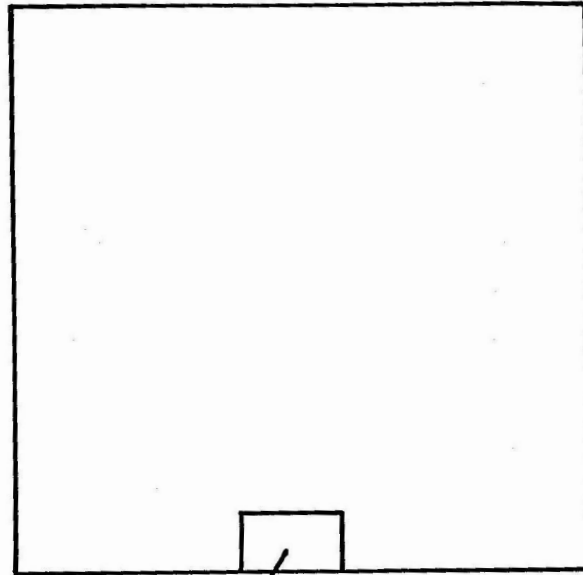

Long's
WORLD

National Capitals are shown in capital letters: WASHINGTON

Population of cities and towns is indicated by symbols thus:

- | | |
|------------------------|---------------------|
| ★ 1,000,000 or over | ◎ 50,000 to 100,000 |
| ■ 250,000 to 1,000,000 | ● 25,000 to 50,000 |
| ○ 100,000 to 250,000 | ○ Less than 25,000 |

Scale at Equator 1:33,000,000 1 inch = 520 miles

Mercator Projection

*Engraved, Printed, Published, and Copyrighted by
Long's Map and Globe Co. Grand Island,
Nebraska. (Printed in the U.S.A.) ©1958*

Notes on format:

This map is backed with cloth and is coated with plastic. It folds into a 14 x 22 inch booklet. Each country is a different color. Unfolded, the map is 3'6" x 4'7" (border minimal)

There is no date on the map, but the code at the bottom of the legend probably indicates the copyright as 1958. Checking various boundary lines and country names, the probable date of production is substantiated.

Face of map:

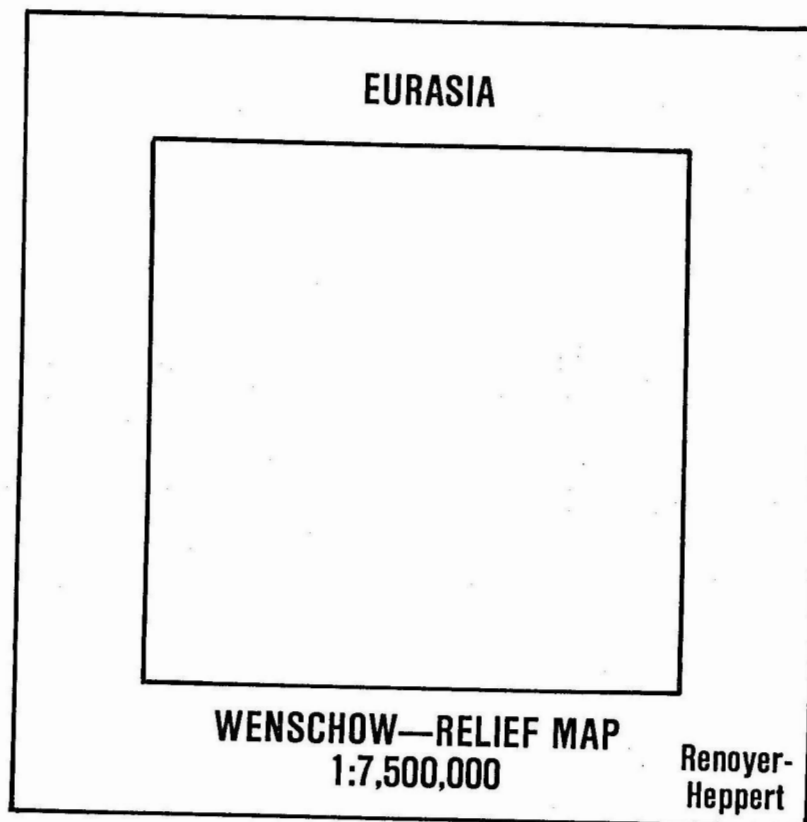

Notes on format:

Through the use of 11 different color gradations, the map illustrates the elevations and declamations of Europe, Asia, and the surrounding ocean floors. The map was produced in Europe by Wenschow and is distributed in America by Renoyer-Heppert. The map is on a spring roller and is 4' x 6' when unrolled. Title on roller: EURASIA RELIEF-LIKE RL23. The publisher's catalog gives no date, neither does the map. The position of some political boundaries indicate that the map was probably produced in the late 1960's.

Face of map:

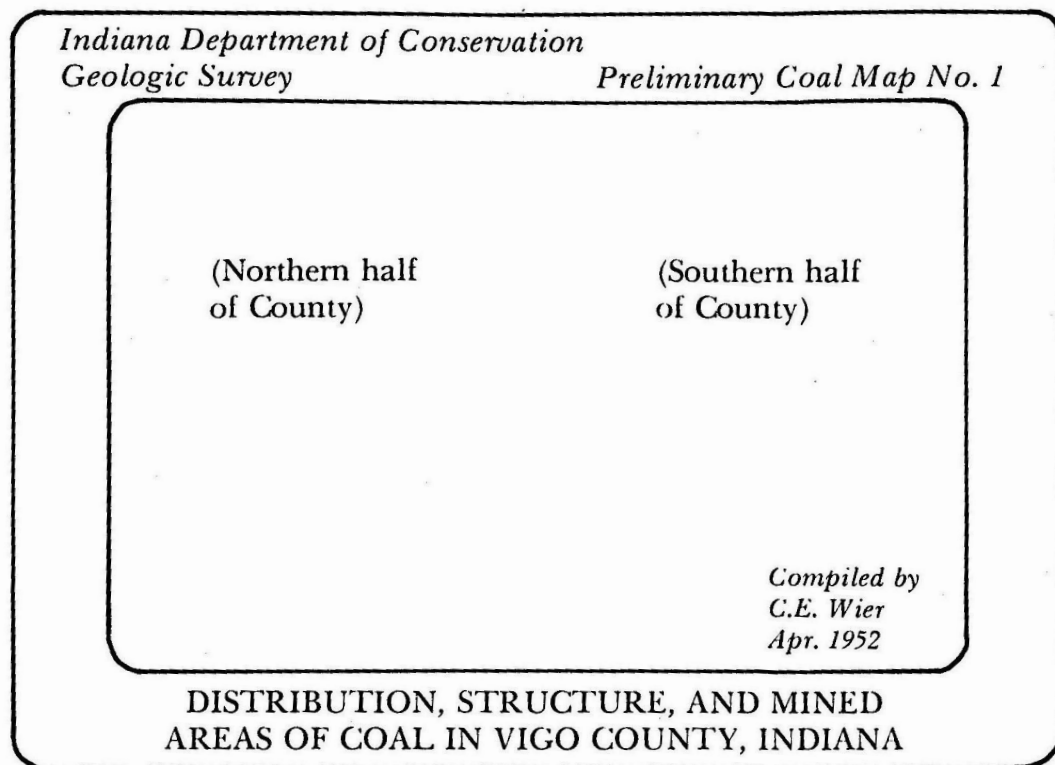

Notes on format:

This black and white 15 x 28 inch map shows boundaries of coal beds, indicates the extent of mining, marks the place of shaft mines, and shows the types of coal beds. The approximate scale is 1 inch to 2 miles.

Information on the border of topographic index map:

UNITED STATES DEPARTMENT OF INTERIOR GEOLOGICAL SURVEY

**Index to Topographic Maps of Alaska
Order Maps by Names Printed in Black and By Series Designation
All Maps Shown on This Index Are Distributed by the Geological Survey**

**ALASKA
1:250,000 series**

Alaska is covered by 153 maps at the scale of 1:250,000—all of which are published.

Notes on format:

The library has 25 maps from the Alaska set but adds to it as time passes. The whole series may or may not ever be acquired. Those that are available have been outlined in red on the index map. The index map and the map series are stored in the bottom drawer of the map case labeled: TOPOGRAPHIC MAPS.

Title page on microfilm:

*An Examination of Selected Variables
Associated With
Elementary Instructional Materials Center*

by

Milton Robert Christison

A thesis submitted in partial
fulfillment of the requirements
for the degree of:

Doctor of Philosophy

(Educational Administration)

at the

University of Wisconsin

1973

Notes on format:

This 100-leaf dissertation is available from University Microfilms, Inc., Ann Arbor, Michigan 73-23, 057. It was originally filmed by the University of Wisconsin Department of Photography.

The microfilm is on one 35mm reel. There is a bibliography on leaves 72-77. The dissertation analyzes data from selected IMCs in the state of Wisconsin.

Title strip of microfiche:

ED042 064	A Study of the Impact of Research on Utilization of Media For Educational Purposes. Final Report. Filep, Robert T. Institute for Educational Development, El Segundo, Calif. 15 Jul 70. 273p.
1 of 5	
ED	
042 064	

Title page of Report:

The Impact of Research on the Utilization of Media For Educational Purposes Sponsored by NDEA Title VII 1958-1968

Final Report

Robert T. Filep

U.S. Office of Education
Contract No. OEC-98-9898-9
Institute for Ed. Development

Notes on format:

The report is from the ERIC collection of microfiche research reports and is reproduced on 5 standard 10 x 15 cm. microfiche.

Microcard title:

917.3

U.S.-SOCIAL CONDITIONS

E167

Balme, Joshua R. (Card 1 of 4)

Letters on the American Republic; or Common Fallacies and Monstrous Errors Refuted and Exposed. .2d thousand.

Enl. ed. London, Hamilton, Adams & Co. [1863] 2p. 1., [iii]-viii, 290p. 19 1/2 cm.

Library of Congress Catalog Card Number 70-34818. Copied from the original in the Library of Congress

Found

Cause

Press

1964

Title page of book:

*Letters on the American
Republic*

or

*Common Fallacies and Mon-
strous Errors Refuted and
Exposed*

by the

Rev. Joshua R. Balme

second thousand Enl. Ed.
Hamilton, Adams, & Co., London

Notes on format:

The four 8 x 13 cm. microcards are printed on both sides.

Summary: The Rev. Balme describes his travels to various parts of the U.S. during the Civil War in an attempt to allay some of the "anti-Northern" feelings rampant in Britain during that period, particularly those concerning slavery. Each chapter is a letter-essay directed to some English newspaper.

Box label:

Product of
3R IM Press
3R Company International Microfilm
Press
New York

CALENDAR OF MANUSCRIPTS
SCHOMBURG COLLECTION

Filmed from the Collections of
THE NEW YORK PUBLIC LIBRARY

Notes on format:

This reel of 35mm negative microfilm contains the complete 513-page index to the famous manuscript collection done during the depression by WPA workers.

The index was filmed in 1967.

Title page on microfilm:

Calendar of the Manuscripts in the
Schomberg Collection of Negro
Literature

Located at
the 135th Street
Branch of the New York Public
Library

Compiled by
The Historical Records
Survey
Works Projects Administration
New York City
1942

Glass microscope slide:

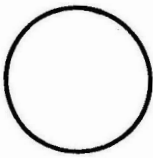
<p>DOG BLOOD SMEAR H2.864</p> <p>Hurlbert, Ross and Co.</p>	
---	---

One glass slide (3 x 8 cm) unstained.

Glass microscope slide:

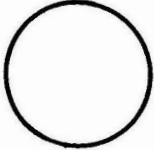
BURTOX/RAMBOSCO SCIENCE COMPANY	
Slide No. ETP-1	
Pig Embryo, 4-5mm. wm.	
Typical Pig Embryology Set	

TYPICAL PIG EMBRYOLOGY SET

1. Pig embryo, 4-5 mm. wm.
2. Pig embryo, 6mm. wm.
3. Pig embryo, 6mm. wm. No. 2
4. Pig embryo, 6mm typ. xs.
5. Pig embryo, 6mm. typ. sag. sec.
6. Pig embryo, 10mm wm.
7. Pig embryo, 10mm. typ. xs.
8. Pig embryo, 10mm. sag. sec.
9. Pig embryo, 15mm. typ. xs.
10. Pig embryo, 15mm. typ. sag. sec.

All slides are glass mounted (3 x 8 cm) and stained.

Glass microscope slide:

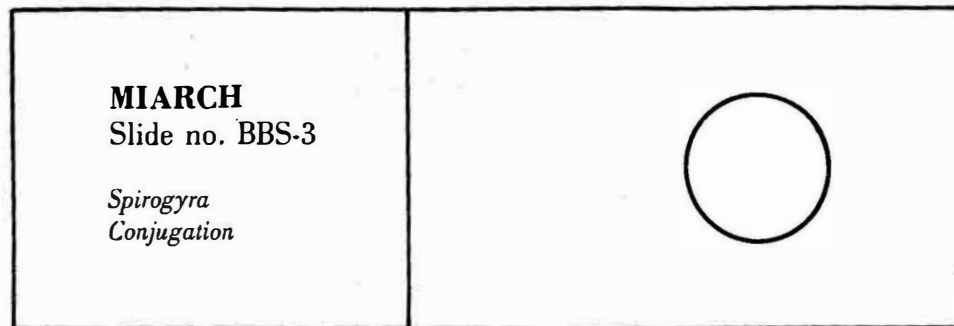

Basic Botany Set

15 slide set (24 specimens)—glass mounted and stained (3 x 8 cm)

Onion root tip. Ls all stages of mitosis
Bacteria. 3 types, rods, cocci, and spirilli
Spirogyra Conjugation
Penicillium, Mycelium and Sporagia
Fern, Antheridia and Archegonia, 2 wm.
Fern, sec. of mature Sorus with Sporangia
Coprinus, Xs thru gills, Basidiospores
Moss Protonemate, wm
Pine male cone with pollen, 1s
Lilly Anther and Ovary, 2 sec.
Typical Monocot and Dicot Leaf, 2xs
Typical Monocot and Dicot Mature Root
Typical Monocot and Dicot stem, 2xs
Wood Fibers Angiosperm and Gymnosperm

MIARCH SCIENTIFIC COMPANY
(No date given)

Planetarium:

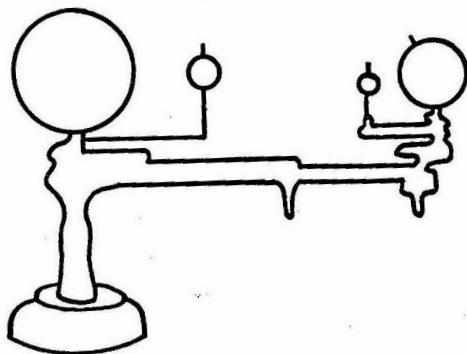

Identification on model:

Systrom and Co.

Catalog description:

Elementary Planetarium

- * Positive slip proof chain and sprocket drive.
- * Shows revolution of the earth and Venus around the Sun.
- * Causes of seasons. . .day and night. . .midnight sun. . .moon phases.

Specifications:

Sun. . . .6" diameter—yellow
Earth. . . .3" diameter—continents in various colors
Venus. . . .2" diameter—gray
Arm. . . .16½" long
Moon. . . .1" in diameter—black

Model SL-400 (Manual operation)

Notes on format:

A 176-page manual by John W. Gross explains the movements of the planets and suggests uses for the model.

Purchased in 1970.

Sculpture:

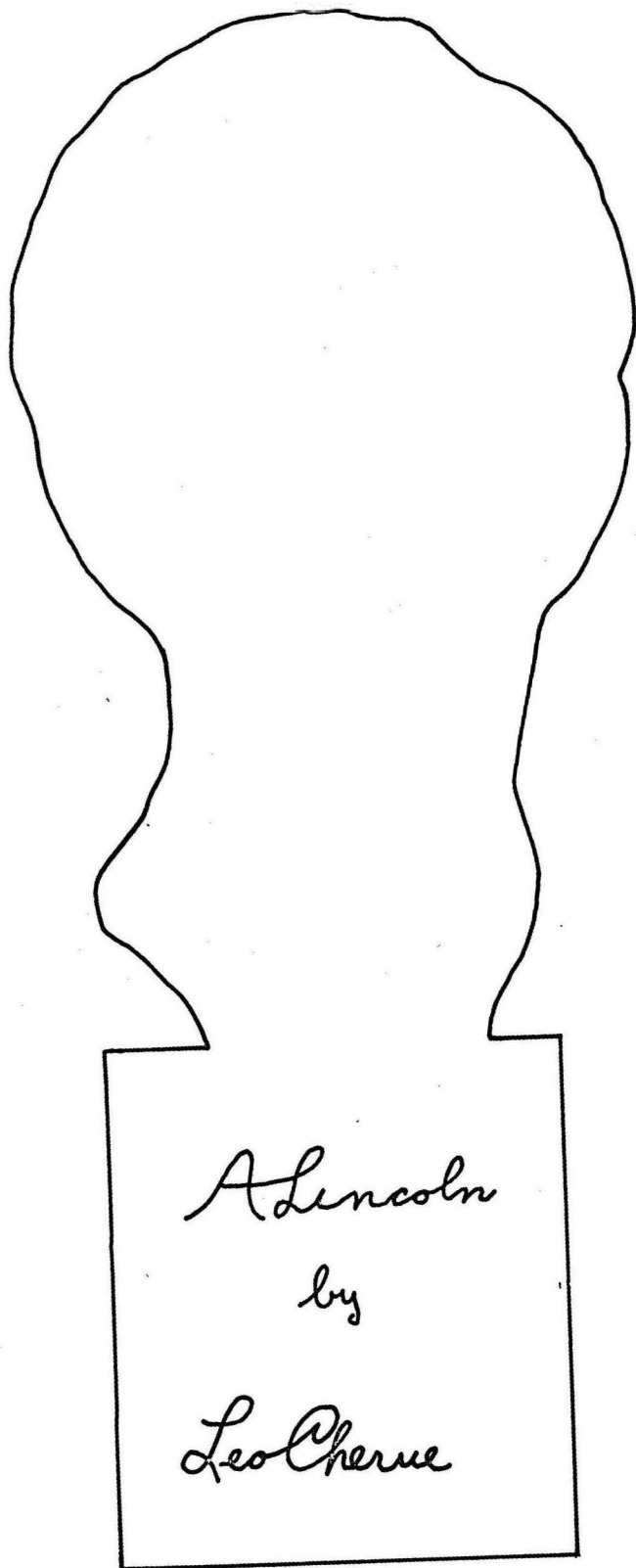

Label pasted to base:

Authentic Reproductions
Copyrighted by

*Salva Museum
Replicas, Inc.*

Salva Studios
New York, N.Y.

Description from producer's catalog:

THE LINCOLN OF THE FINAL SACRIFICE by
Leo Cherne (American Contemporary). After
the last photograph by Alexander Gardner.
Bronze orig. at Lincoln Museum. LC-20 8"
Bronze.

To scale 1:3

Box front:

COMP—DIGI 1

First real operating digital computer in plastic.

See logic in action. . .

Now for the first time see and understand the operations hidden in the circuits of a giant computer and learn the language of computers.

A binary computer you can program.

See how the computer adds, subtracts, shifts, complements, multiplies, plays challenging games, memorizes, does the missile count down and re-entry.

*Montgomery House
C.E.R.S. Inc. 1965
New York*

Notes:

A 10 x 4 x 4 in. plastic, red and white model with numerous moving plastic and wire parts. A 28-page instruction manual and a one page parts list accompanies the model.

Model:

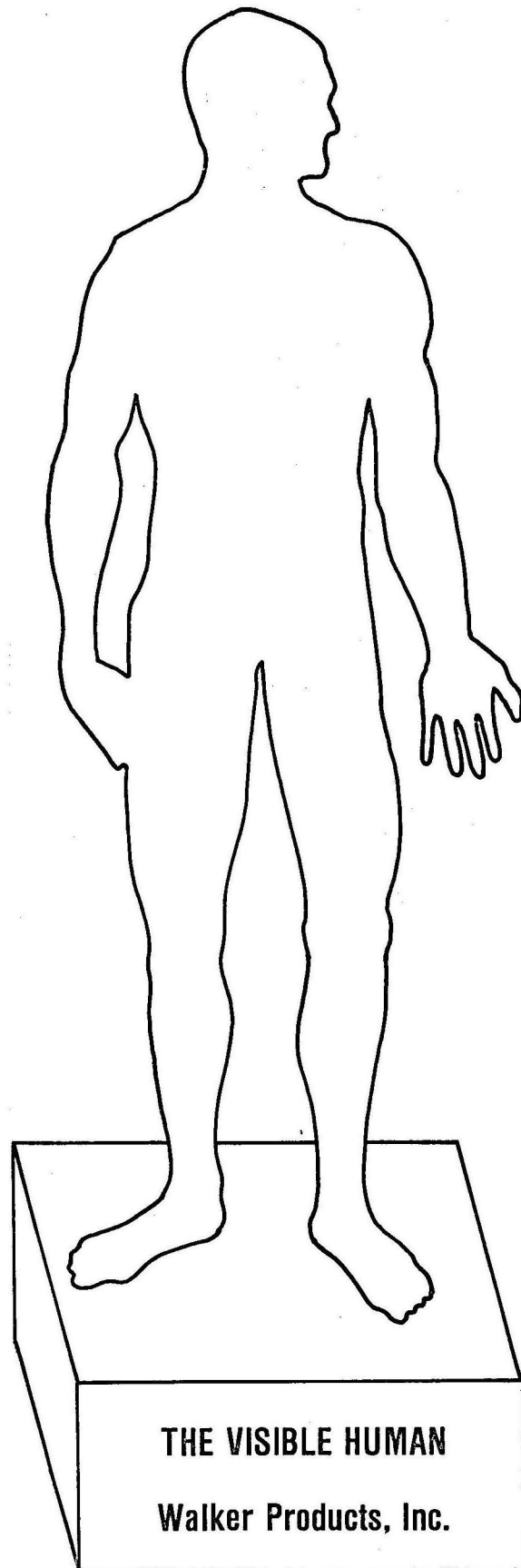

Notes on format:

Outside shell of human body is transparent plastic so that inner organs and skeleton are plainly visible. Shell can be removed in several sections. Each organ and the various bones are separate pieces and can be removed or fitted together. Organs are painted in life-like colors and the skeleton is white.

All pieces are plastic.

The entire model including the one inch base is 18 in. tall.

Red Riding Hood Puppet:

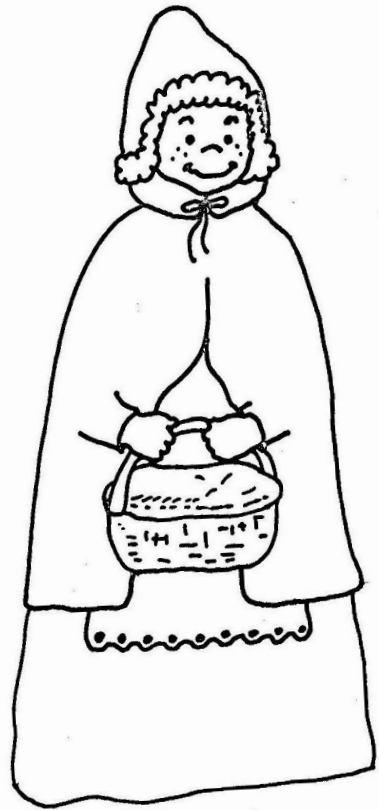

Notes on format:

Little Red Riding Hood is a stuffed puppet made by Alice McGowan from a commercial pattern in 1974. The puppet's skirt covers up the grandma puppet. Grandma's lacy cap comes off to expose the head of the wolf:



The entire puppet is 18 inches tall.

Red Riding Hood turned upside down—Grandma:

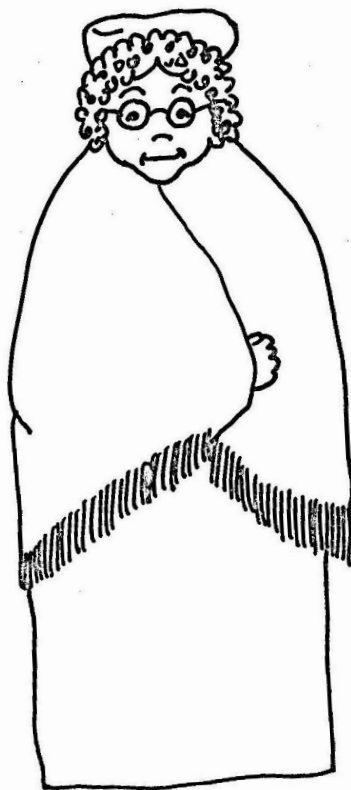

Grandma with cap reversed—Wolf:

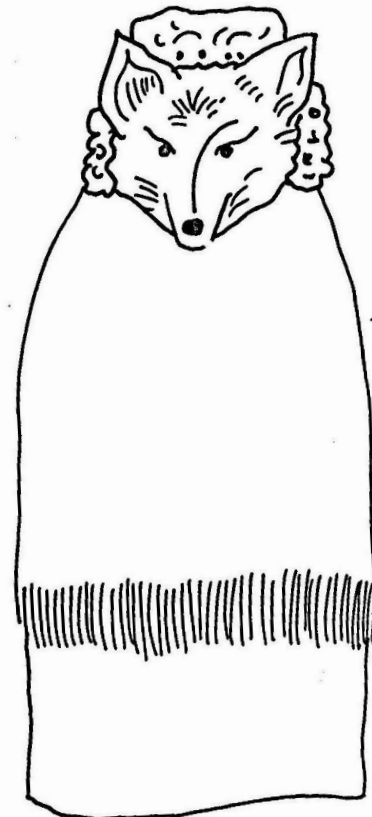

Heart model:

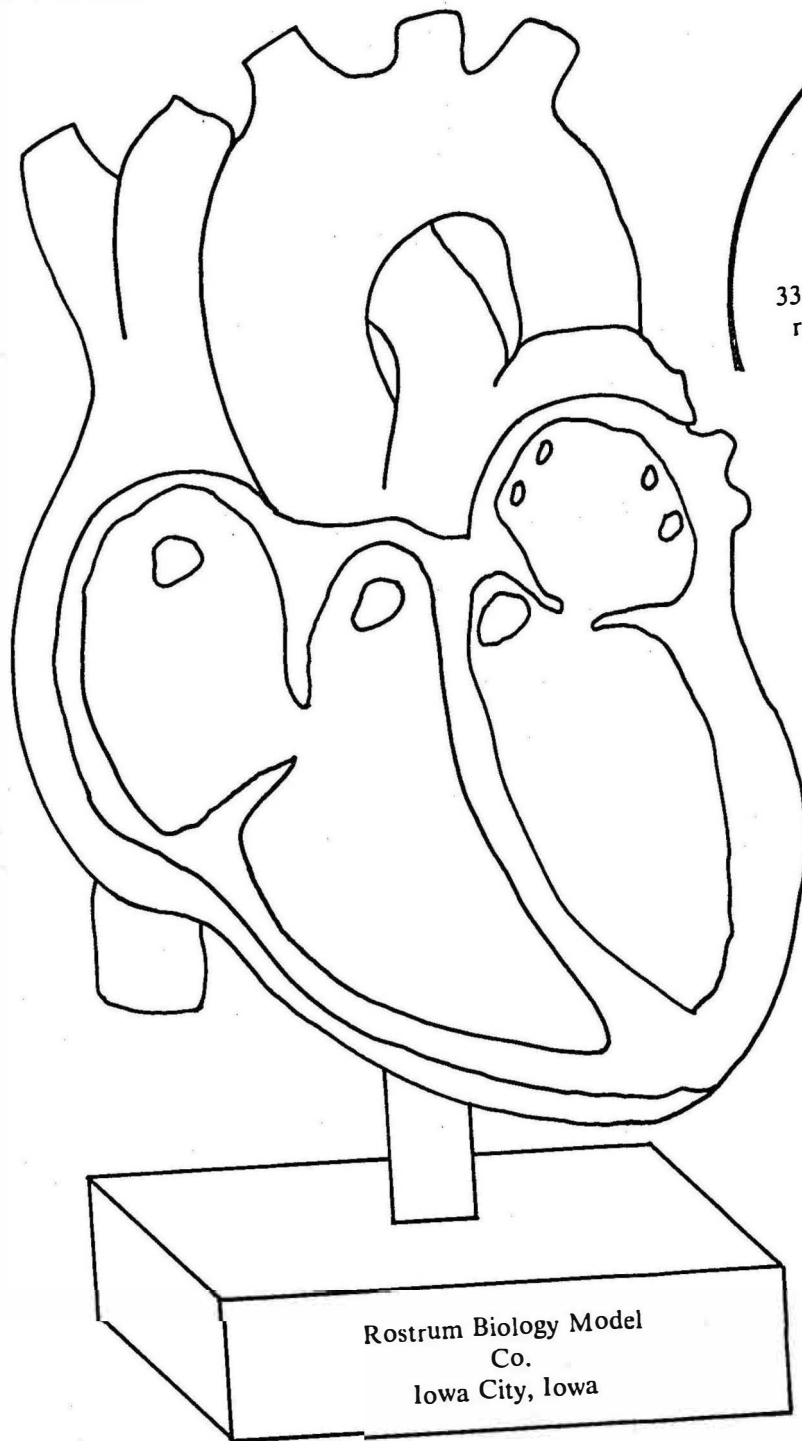

Record label:

*Rostrum Biology
Model Co. Iowa City, Iowa*

Talking Models: The HEART

33 1/3
rpm



Mono.

Notes on format:

Record is 7 in. in diameter.
Manual is 8 pages in length.

The model has many
interlocking parts in simulated
color.

The manual lists the model
number as 70140 with record
62002.

Box title:

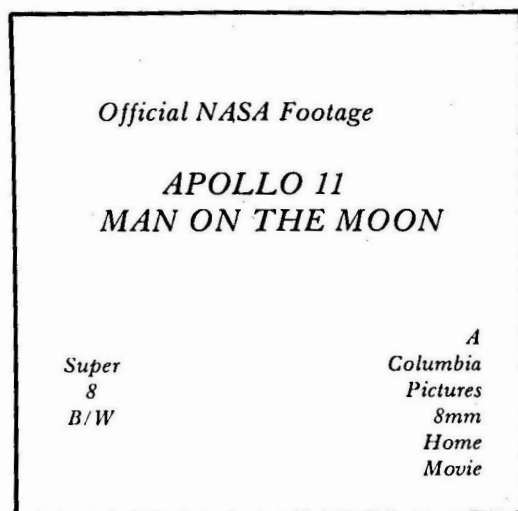

Notes on format:

This black and white super 8mm movie comes on a single 5" reel. The movie is 9 min. in length. There is no accompanying guide. The movie is silent and explains various scenes with captions.

Reverse side of box:

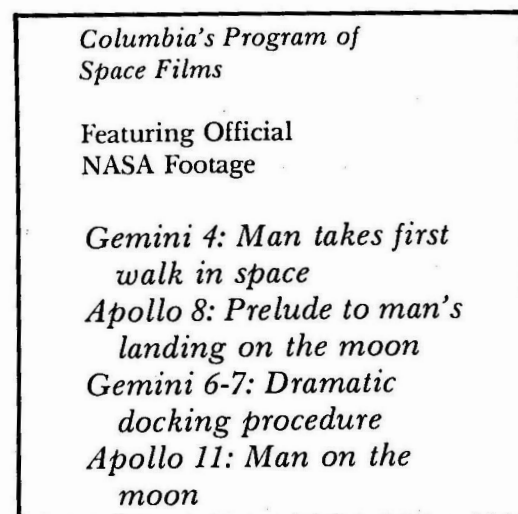

Title frame:

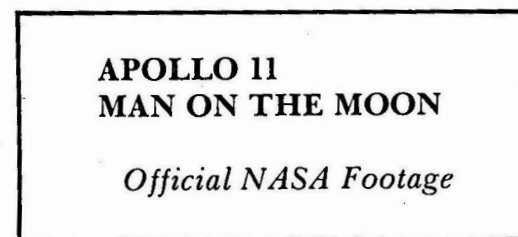

Title Frame:



Cartridge label:

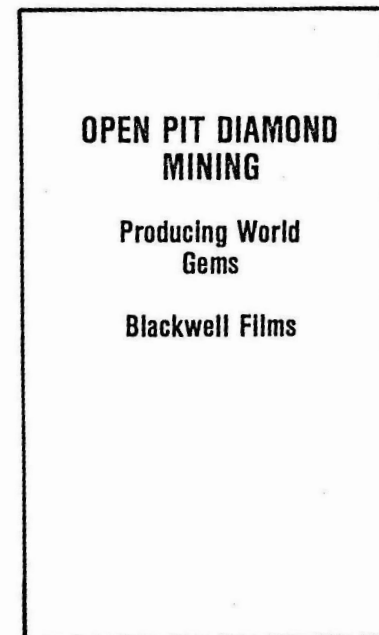

Summary on cartridge:

Depicts the open pit mining and the mechanical and hand processing of raw materials, showing how the diamonds are extracted from the earth, sorted, inspected, and weighed.

Grade level: Jr. high school

Notes on format:

A super 8mm sound film in a Technicolor cartridge. 16 minutes in length. In color.

Notes: The 1973 Blackwell Films catalog has the following note on page three illustrating the Producing World Gems Series: "New releases by Blackwell Films." Other titles in the same series: Cutting and Polishing Gems; Rough Stone-Cut Gems; Tools For Gem Cutting and Polishing. Note at the bottom of the page: "Other titles to be released soon."

Title Frame:

RVP Television
Presents:
IT'S SAFE TO SAIL
(Movement, no. 8)

Credits Frame:

Copyright:
RVP Television Inc.
135 4th Ave.
New York

MCMLXIX

Title on film can:

IT'S SAFE TO SAIL

Title in publisher's brochure:

Movement Series:

1. We Like to Ride
2. My Car
3. Trucks That Move
4. Passenger Trains
5. Riding the Bus
6. Airplane Travel
7. Bicycle Safety Habits
8. It's Safe to Sail

Summary blurb on printed brochure:

Illustrates and discusses the development of water transport, the different kinds of boats and ships, their shape, propulsion, loading, and water safety.

Grade level: 1-6.

Notes on format:

A 16mm black and white film. 20 minutes in length with sound.

Title Frame:

LOOKING FOR MEANING
Producer: Ron Bowley
Morwin Films
1960

Title on film can:

Looking For Meaning In Life.

Credits Frame:

John Thomas Films
New York
for
Morwin Films
Toronto
1972

Summary in film catalog:

An impetuous young man leaves his job in a city gas station to build a cabin and live off the land in the country. His failure to succeed proves that more than superficial knowledge is needed to cope successfully with important decisions.

Grade level: high school and college.

Notes on format:

A black and white sound 16mm film—32 minutes in length. Study guide included.

Title frame:

BROWN WOLF
*based on the story by
Jack London*

Film can:

BROWN WOLF: *Based on the story by Jack London.*

Worldwide Film Center
London Toronto

U.S. Release by Fine Arts Films

Credits frame:

Worldwide Film Center
London and Toronto

1965

Summary from teacher's guide:

An adaptation of Jack London's story in which the conflict between the refinements of civilization and the call of the wild is dramatized as two people attempt to possess a wild dog.

Grade level: upper elementary, junior high school, high school.

Notes on format:

A 16 mm sound motion picture in color. 26 minutes in length.

Title frame:

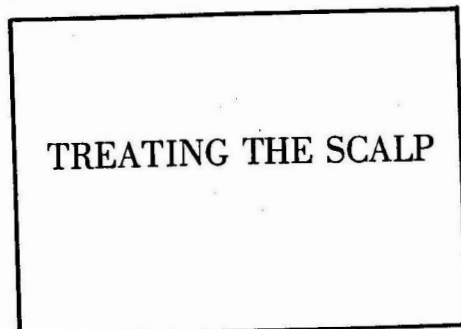

Credits frame:

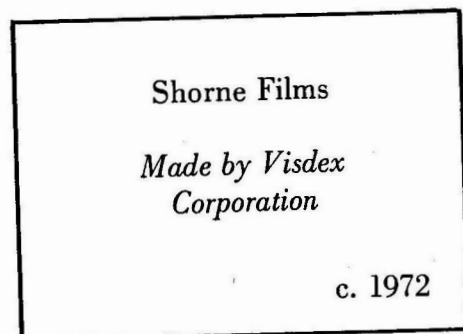

Container label:

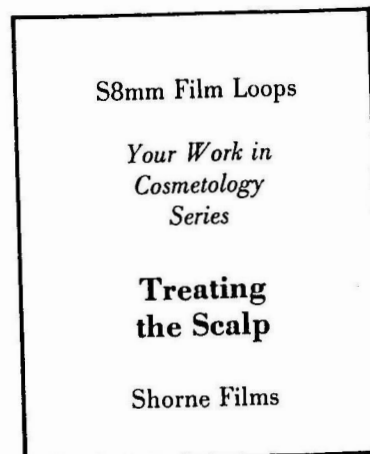

Summary on cartridge:

Illustrates procedures for giving
an oil scalp treatment.

Grade level: high school—vocational school

Notes on format:

An 8mm film (super) in color with no sound. 4 minutes in length. Packaged in a Kodak Super 8mm cartridge.

Oil painting:

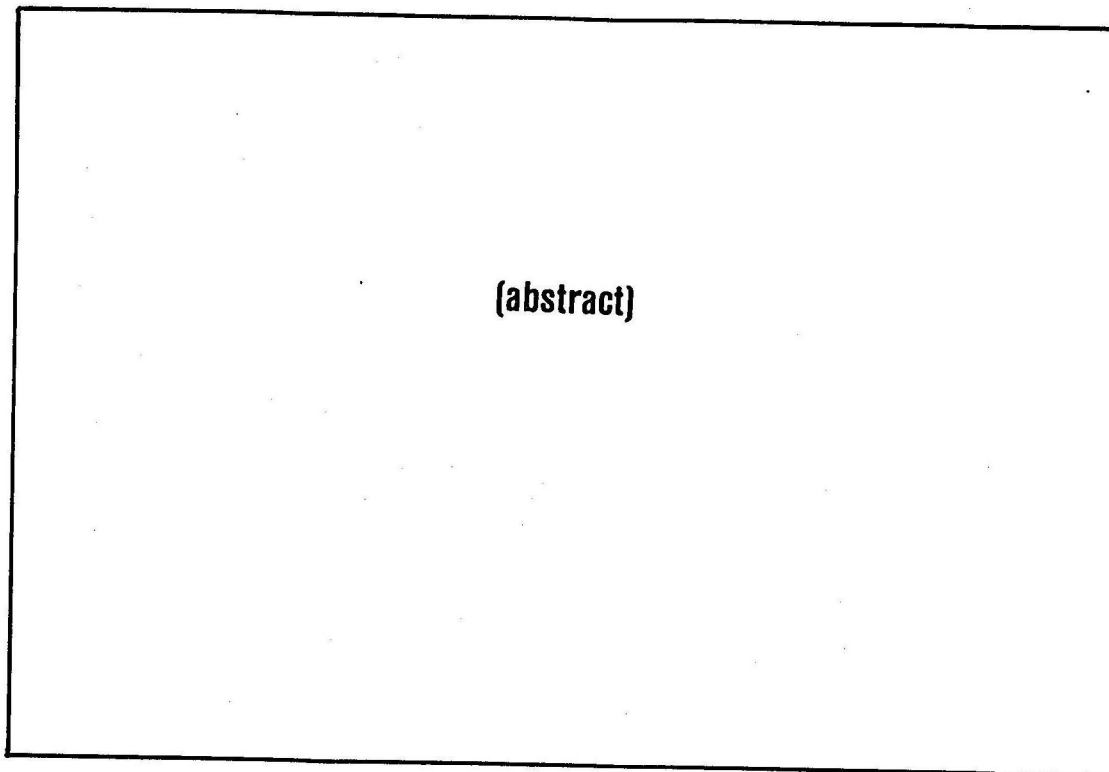

Business card tacked to back of painting:

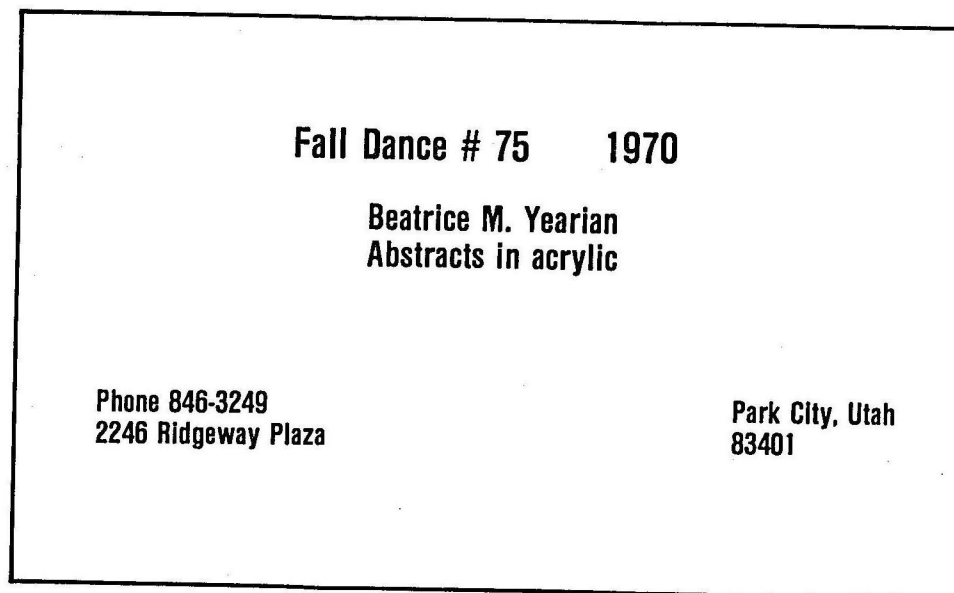

Notes on format:

A borderless, framed, abstract painting in acrylic.

Colors: purple, orange, yellow, and green.

36 x 45 inches.

Watercolor painting:

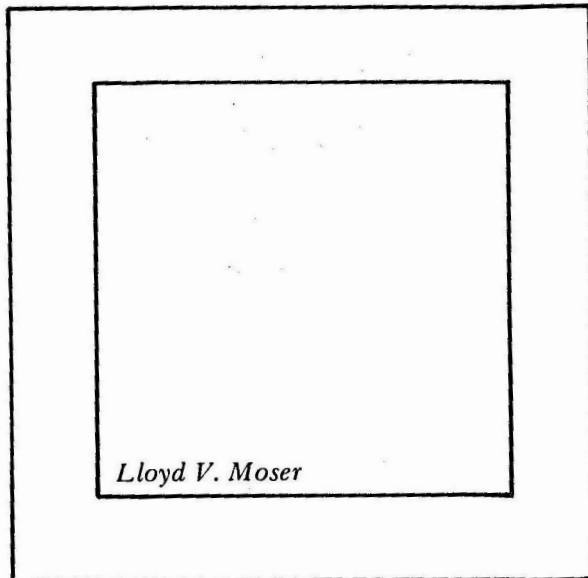

Notes on format:

A 10 x 12 inch watercolor painting in an 18 x 20 inch frame.

The painting has a piece of glass protecting the surface.

Subject of painting: Trees near a small river with low rolling hills in the background.

Moser is a native of West Lafayette, Indiana and paints in his home from color slides.

Information written on the back of the frame:

Taneycomo in the Ozarks

Lloyd V. Moser

Custom Framed by Ray B. Crepps,
West Lafayette, Ind., Feb., 1971

Reverse side of art print:

PIERRE-AUGUSTE RENOIR
1841-1919

Auf der Terrasse
Sur la Terrasse
On the Terrace
Al balcone

© 1960 by KUNSTSREIS LUZERN
The Art Institute, Chicago
Printed in Switzerland
by Mengis and Sticher, Lucerne
A Habrams Color Print

Notes on format:

An 18 x 26 in. color reproduction on heavy paper. The print was purchased from the Habrams Company which is a U.S. distributor of art prints from many foreign printers and publishers.

Cover of picture portfolio:

Clark Bronson

Portfolio of Bird Sketches

Beautiful color pictures of
seventeen North American
birds which can be removed
for framing.

Field Arts, Inc.
© 1968

The pictures are stapled into a bright paper cover. Each picture is perforated for easy removal. Picture dimensions are 11 x 14 inches. The Color sketches are signed by the artist.

Portfolio envelope:

Portfolio No. 5

*MASTERPIECES FROM THE
SAMUEL H. KRESS
COLLECTION*

15 color reproductions
from the
NATIONAL GALLERY OF ART

price: \$2.85

From the descriptive folder:

Portfolio No. 5—Masterpieces From the Samuel H. Kress Collection, 1956. Descriptive text by Fern Rusk Shapley concerning these gifts from the Kress Foundation to the National Gallery of Art.

Sample note on reverse side of painting:

*Titian. Doge Andrea Gritti
(Italian, 1477-1576)
Kress Collection
National Gallery of Art*

Notes on format:

The portfolio contains 15 11 x 14 inch color reproductions. The descriptive folder is 3 pages and lists the contents as follows:

Angelico, Fra, and Fra Filippo Lippi

The Adoration of the Magi

Bosch

Death and the Miser

Botticelli

Giuliano de'Medici

Bruegel, Pieter the Elder

The Temptation of Saint Anthony

Chardin

The Attentive Nurse

Clouet

"Diane de Poitiers"

David, Jacques-Louis

Napoleon in his Study

Dürer

Madonna and Child

Giorgione

The Holy Family

Greco, El

Christ Cleansing the Temple

Grünewald

The Small Crucifixion

Memling

The Presentation in the Temple

Poussin

Holy Family on the Steps

Tintoretto, Jacopo

The Conversion of Saint Paul

Titian

Doge Andrea Gritti

Loose sticker inside clear plastic study print envelope:

NATURE STUDY PRINTS
Set No. 4
ANIMALS OF EAST AFRICA

Wright House

developed by
General Education Co.

for

E.M. Wright and Co.,
San Francisco, Calif.

Notes on format:

13 full color photographs of East African mammals.



Purchased from E.M. Wright and Co.

13 x 18 inches.

All study prints are by Rue.

Reverse side of sample study print:

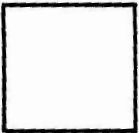
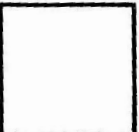
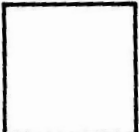
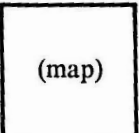
THE SPOTTED HYENA (CROCUTA CROCUTA)
Swahili name—Fisi

 Hyena pup	(description)	 Hyena
 Young Spotted Hyena		 Hyena
 (map)	© 1969 General Education Co., Reno, Nevada Author and photographer: Leonard Rue, III Nature Study Prints—Set No. 4—Animals of East Africa	 (habitat)

Study print cover:

BIRDS WE KNOW	
<i>Group 1</i>	<i>Contents:</i>
Picture Study Prints™ Set SR-509 <i>Winger</i>	*Great Horned Owl *Cardinal *Blue Jay *Redwing Blackbird *Mourning Dove *Brown Thrasher *Robin *Hairy Woodpecker
<i>PSSP-100 Basic Science Series</i>	

Notes on format of study prints:

The reverse side of the study prints lists the title as given in the contents on the cover. The bird's habits and characteristics are described, questions and answers about the bird are given, suggestions for utilization, and a list of correlated filmstrips are provided.

Publishing data: Winger Educational and Training Products © MCMLXIII. Each color print is 13 x 18 in.

Record jacket:

WINGER
Educational and Training Products
Talking Picture Study Prints™
PSSP-100 Basic Science Series
<i>Common Insects, Group 1</i>
<i>Spring Wild Flowers, Group 1</i>
<i>Wild Animals, Group 1</i>
<i>Birds We Know, Group 1</i>
<i>Pets</i>
<i>Farm and Ranch Animals</i>

Notes on format of record:

The record jacket appears to be a standard jacket used for any records in the series.

The record is 12 in. and is mono.

The study prints can be purchased and used independently, but the record cannot be used without the study prints.

Record label:

WINGER	
<i>Educational and Training Products</i>	
For use with Talking Picture Study Prints SR-509	
BIRDS WE KNOW	
Group 1	
33 1/3 rpm	XGTV 141341
Time: 15:05	○
Side 1	Band 1—Great Horned Owl Band 2—Cardinal Band 3—Blue Jay Band 4—Redwing Blackbird

Card inside plastic envelope which
houses all flannel-board figures:

No. 152 THE THREE PIGS

Wallace Products

**flannel board
stories**

Wallace Products Co., Lima, Ohio

Notes on format:

An information sheet has the story, notes for presentation, and suggestions for use and child participation. The 10 flannel pieces are on colorfully printed cardboard with fuzz backing for adherence to flannel board. One character has a note: © 1964 Wallace Products Co., Lima, Ohio.

Starfish skeleton:

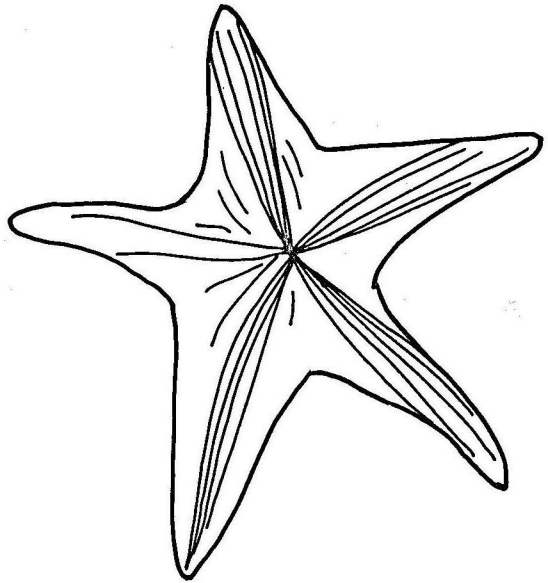

Notes on format:

This starfish skeleton was found on the Atlantic ocean beach near Miami, Florida. From tip to tip, the skeleton measures 9 inches.

Cypress tree root tip:

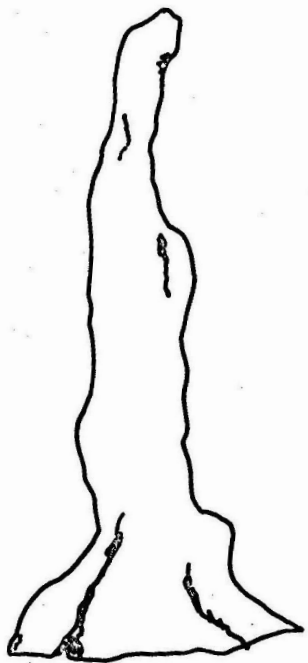

Notes on format:

This cypress tree root end has been cut at 25 inches, cleaned, and finished to produce an interesting natural sculpture.

Collected and finished by Clark De La Roche in 1969 in the state of Alabama.

Jar of specimens:

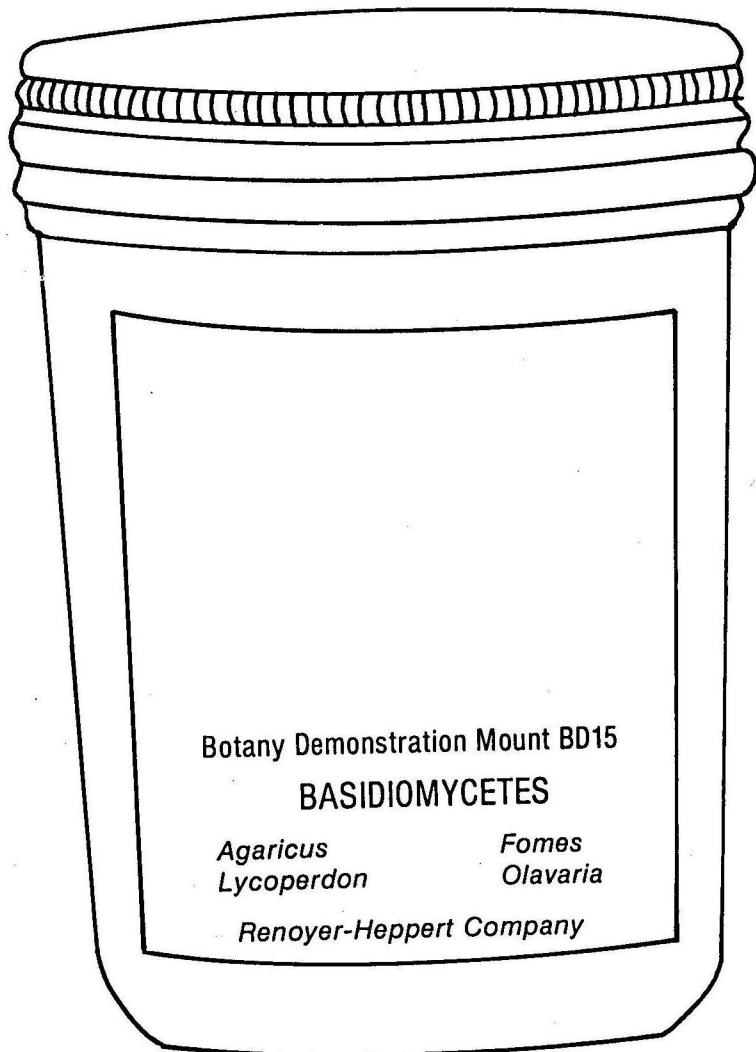

Notes on format:

The four fungi in the bottle are mounted on two strings and tied to a glass plate. The bottle is full of liquid preservative.

Purchased in 1972.

Label on jar lid:

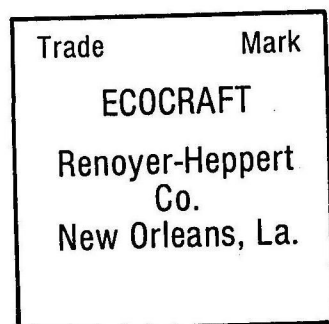

Box title: none

Grade level: none specified

Notes on format:

Cardboard box contains various articles of Mexican clothing and accessories: 1 shawl, 1 dress, 1 sombrero, 1 pair of sandals, 10 pieces of jewelry, 1 handcarved leather belt, 1 colorful shirt.

Notes: An anonymous donor gave the items to the library in 1972.

Actual size hornbook:

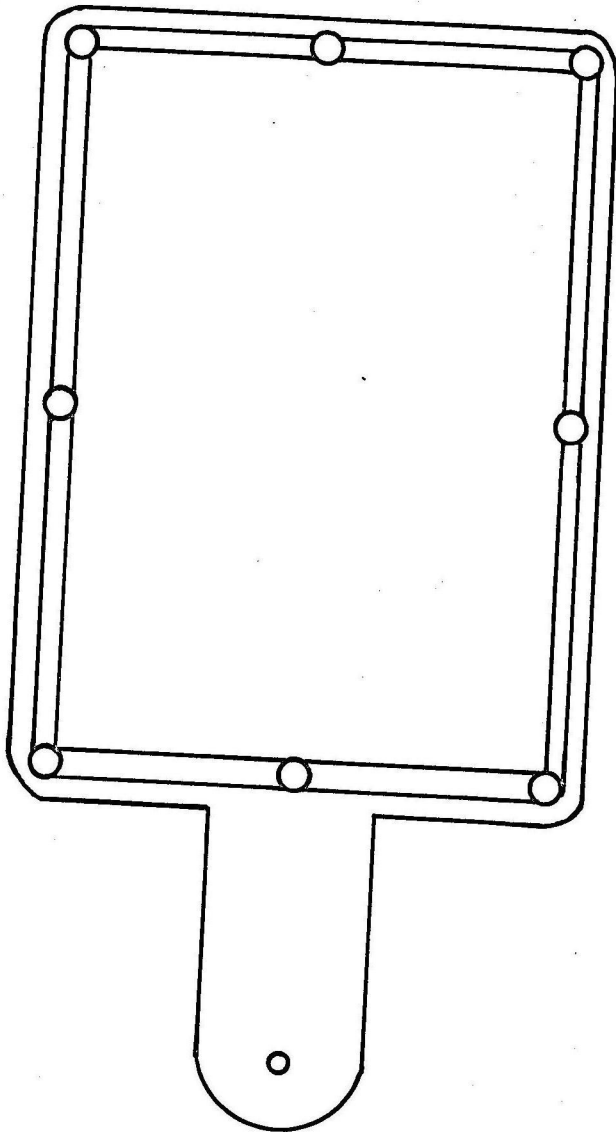

Notes on format:

This hornbook is a copy of an authentic hornbook. Printing is protected by a plastic sheet riveted to the wood.

The hornbook was donated to the library in 1969 and no data on its maker is available.

Title slides:

A TIME TO DECIDE

A Program About
Industrial Cooperative
Training

Produced by:
Audio-Visual Center
Indiana St. Univ.
Terre Haute, Ind.

D. Bunte
narration

M. Kerper
photography

© 1971 ISU Research Foundation

Director:
P. Lassiter
Developed by:
Dr. Howard McVickery
Industrial Education
Indiana St. Univ.

Notes:

92 color 2 x 2 slides with a narration on cassette (20 minutes in length). A printed script is included.

Summary: The program describes ways that high school students may gain practical vocational experience three hours per day during the regular school year. Students apprentice in actual business establishments in cooperation with the school's industrial arts and business departments.

A TIME TO DECIDE

Slide box cover:

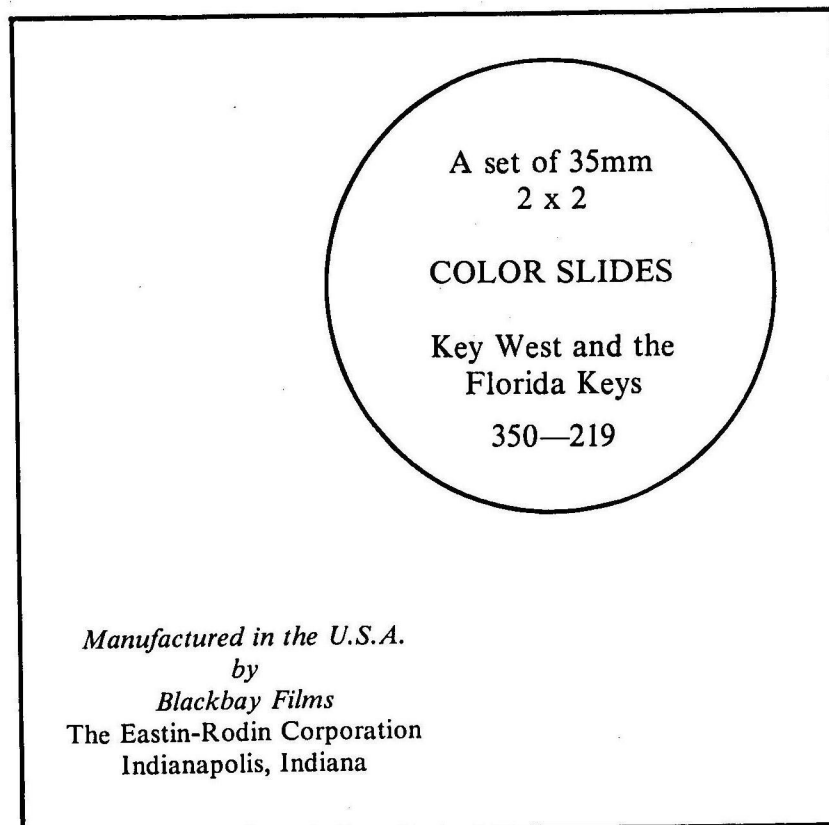

Sample slide mount:

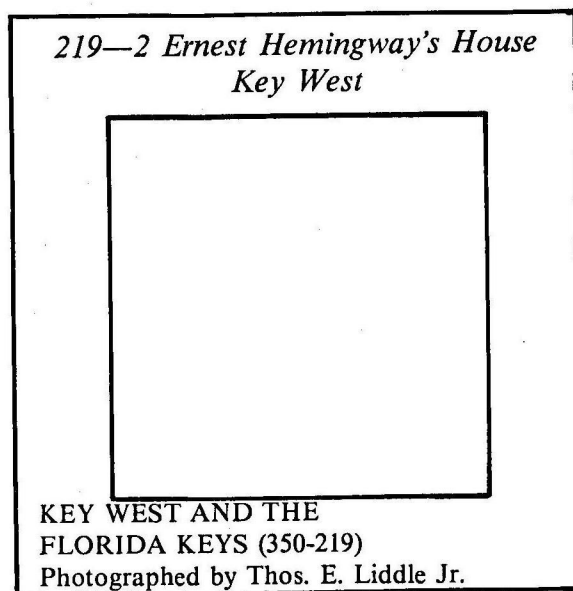

Notes on format:

26 slides. All list Thos. E. Liddle Jr. as photographer. Boxed in 4x4 in. box in 4 compartments.

Slide list inside box:

1. Key West lighthouse, Key West
2. Ernest Hemingway's house, Key West
3. Oldest house in Key West
4. Typical old house, K.W.
5. Typical old house, K.W.
6. East Martello Tower Fortress and Museum, K.W.
7. Southernmost house in the U.S., Key West
8. West Martello Tower Fortress Ruins, K.W.
9. Shrimp fleet, K.W.
10. Shrimp fleet, K.W.
11. Shrimp fleet at sundown, K.W.
12. Sunset, Key West
13. American Indian Museum, Marathon, in the Florida Keys
14. Marathon boat yard, Florida Keys
15. Marathon fishing docks, Florida Keys
16. Shrimp nets, Marathon fishing docks
17. Anchor and cannon from ancient Spanish Galleon sunk in the Keys
18. Bahia Honda Bridge on the Overseas Highway to Key West
19. Guy Lombardo's Key Colony beach
20. Coral seas, sparkling sands and lush vegetables of the Keys
21. A millionaire's hideway in the Keys
22. Seven mile bridge in the Keys
23. Coral beaches and man-made islands in the Keys
24. The Atlantic Ocean from the Keys
25. Fishing camps on the Keys
26. Overseas highway linking the Keys at Marathon

Box label:

none

Title slide:

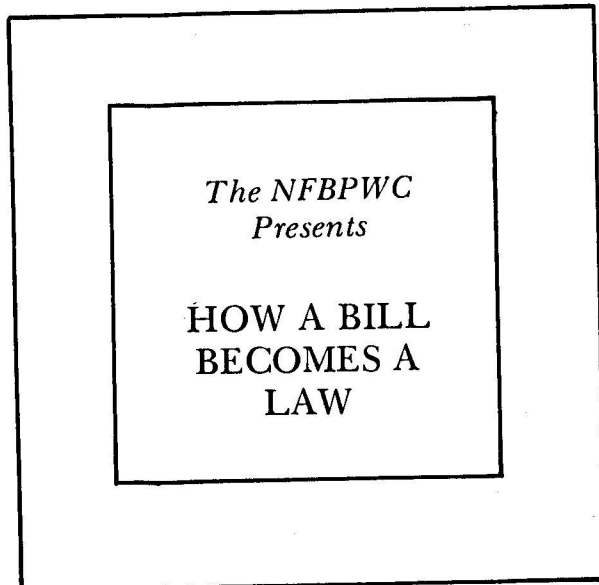

End slide:

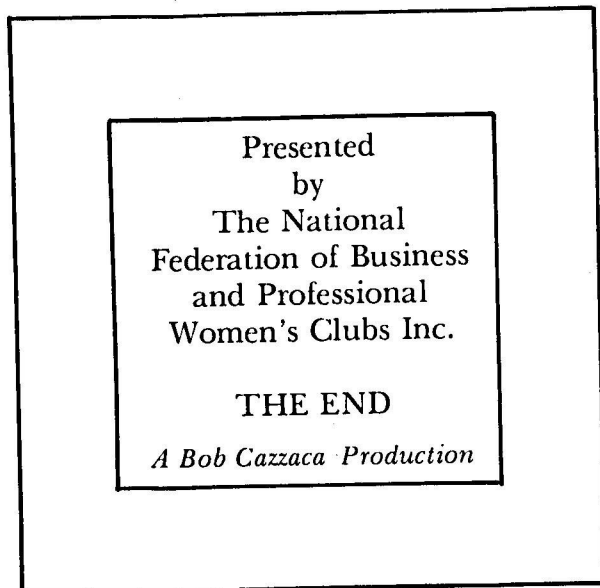

Notes on format:

33 color 2 x 2 in. slides are accompanied by a script giving a suggested narration for each slide. There are no suggestions for use.

Purchased in the late 1960's.

Script cover:

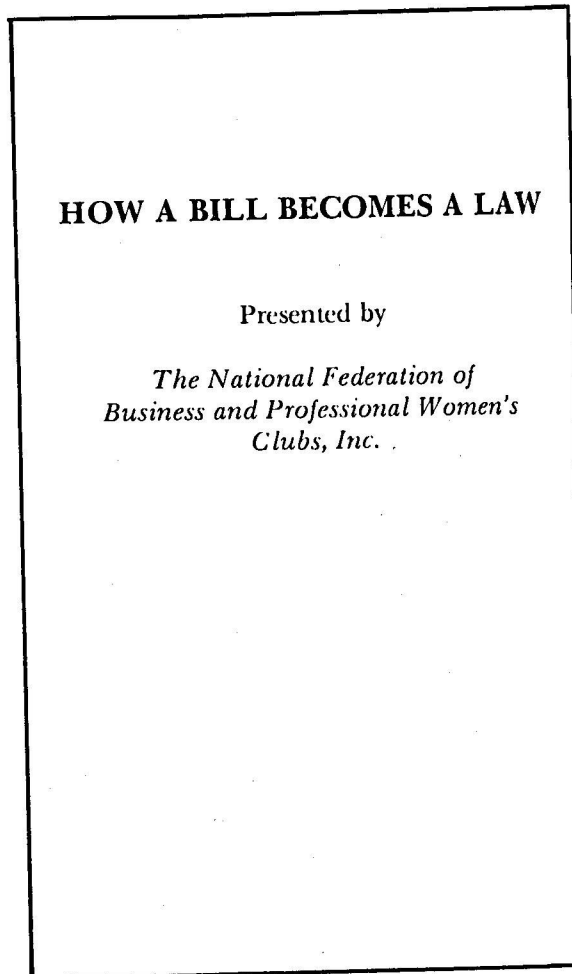

Box lid label:

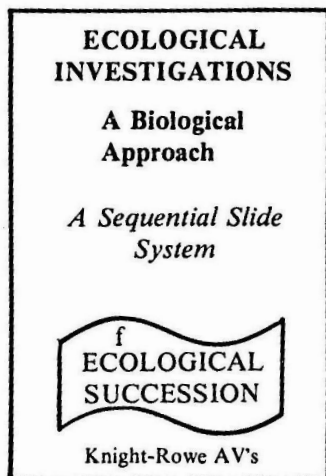

Label on Kodak slide tray:

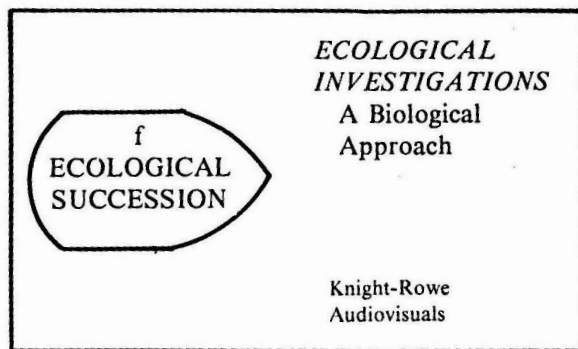

Notes:

The 58 captioned and colored 2 x 2 inch slides are loaded in a standard Kodak Carousel slide tray. Title page of the 52 page manual contains a picture-by-picture explanation of the slide caption and the concept being introduced. The slide set is one of six sets in the Ecological Investigation series. Other sets in the series include: Problems in Ecology; Ecological Populations and Communities; Nutritional Relationships in Nature; Material Cycles in Nature.

Title slides:

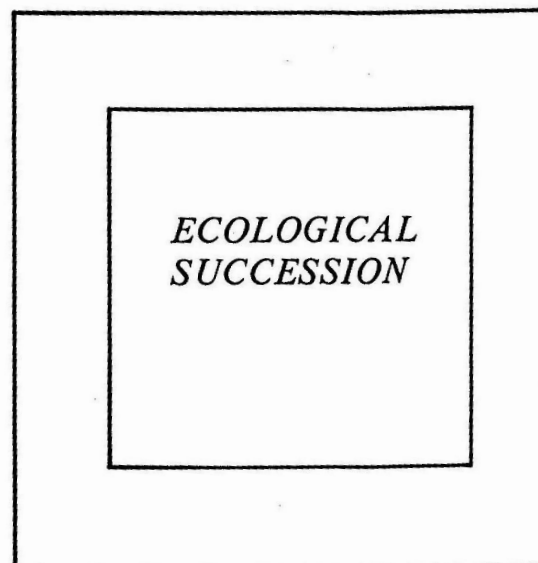
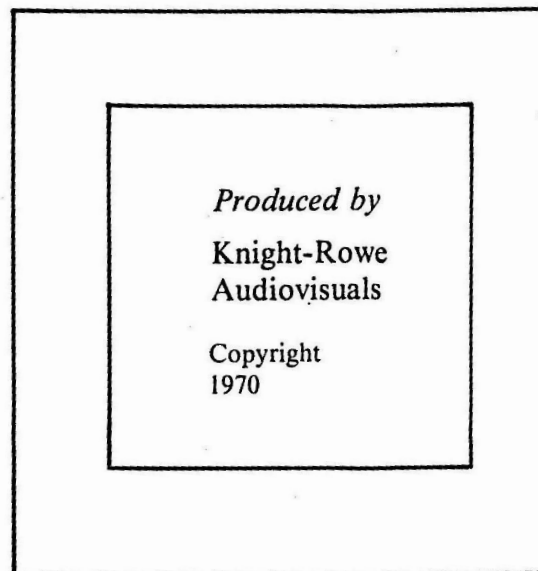
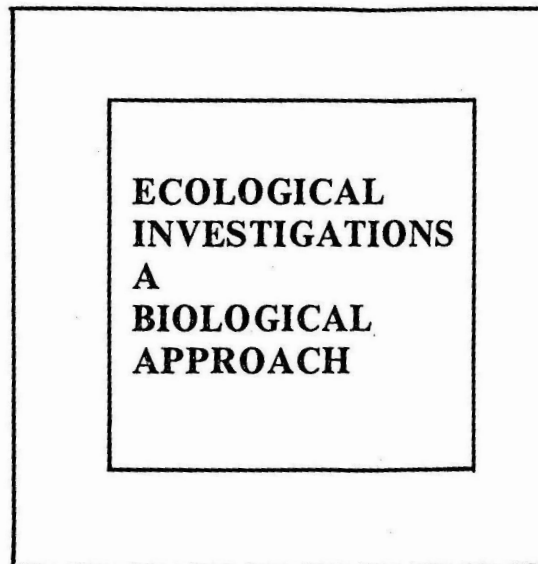

Title slide:

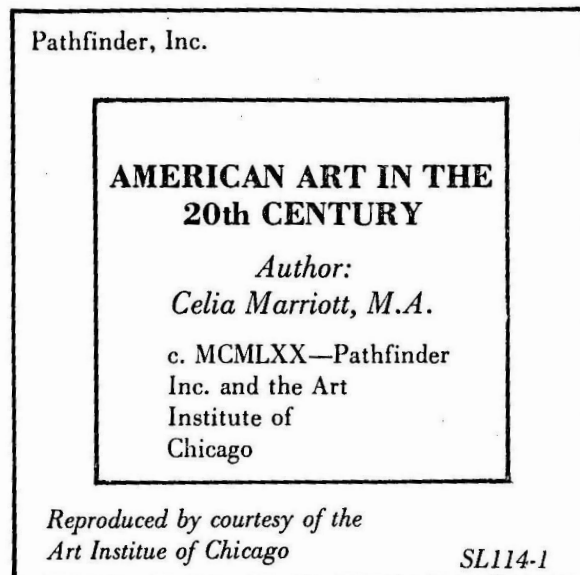

Guide title page:

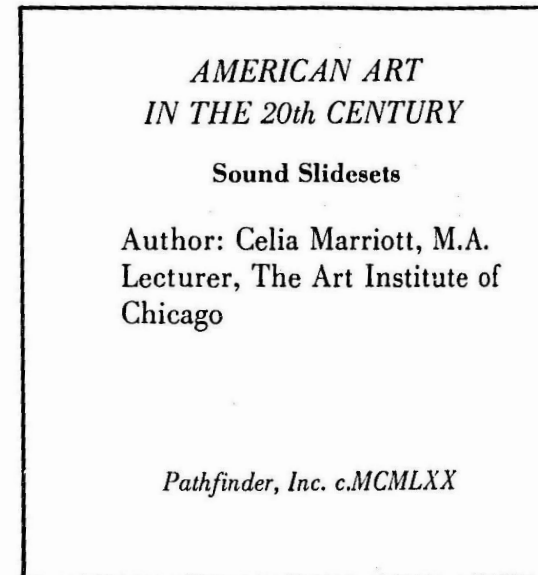

Sample slide:

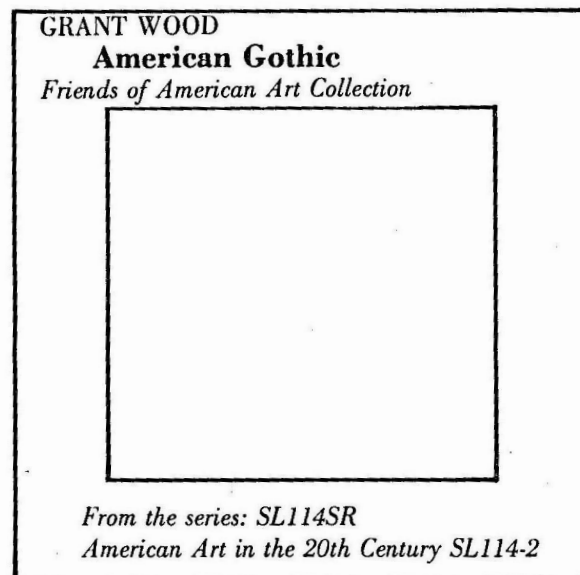

Note:

Set contains 50 slides, color, 2 x 2 inches. Ms. Marriott selected the paintings to be photographed and wrote the script for the narration. The slides are in a looseleaf-type plastic folder. The record is separate. A 10-page guide lists: artist, title, source of acquisition, and gives a 100 word description which matches the narration on the record.

Note from producer's catalog: Provides a comprehensive overview of Abstract Expressionism and later American art styles. Most artworks were created in 1950's and 1960's. Includes: Wood, American Gothic; deKooning, Excavation; Hopper, Night Hawks; Demuth, . . . the Home of the Brave; Segal, Couple on a Bed; Albright, That Which I Should Have Done I Did Not Do; Bonticou, Untitled; Albers, Homage to the Square: Yellow Signal; Diller, First Theme; . . .and others.

Record label:

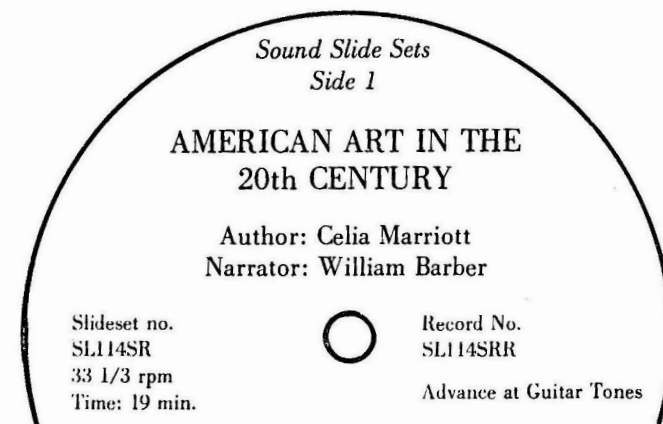

After previewing a complete set of transparencies, only one transparency was selected for purchase:

Transparency frame:

Exclusive National Distributor:
Eastern Educational Services
1340 Ralph Ave. Eau Claire, Wisc.

*Audio/Visual
products of RAF
Riley Art and
Film Corp.*

**WORLD ALIGNMENTS
(Treaty Organizations)**

©1964 RAF

*Projection Aid No. 258
WORLD HISTORY
World Alignments*

Notes:

One transparency in color—10 x 12 in. with four overlays. Basic cell is a world map. Overlays include: Soviet Communist Bloc; Warsaw Pact; Communist Yugoslavia; and Western Nations (which includes symbols for the OAS, NATO, SEATO, etc.)

Transparency set folder:

Instructive
Teaching
Transparencies

851—B Reading Maps

Complete Series Listed Below:

- 850—1 Maps and Globes
- 851—5 Introduction to Latitude and Longitude
- 851—6 Latitude and Longitude on the Globe
- 851—10 Topography
- 851—11 Elevation
- 851—12 Scale
- 851—13 Key and Index

The Instructive Corp. Kansas City, Mo.

Note:

Each of the 10 x 12 in. color transparencies has several attached overlays. Each is in a clear plastic pocket which includes a one-sheet teaching guide and a one-sheet suggestions sheet for effective transparency presentation.

Sample transparency:

Instructive
Teaching Transparencies

Reading Maps: No. 851-13

Key and Index

The Instructive Corp. Kansas City, Mo.

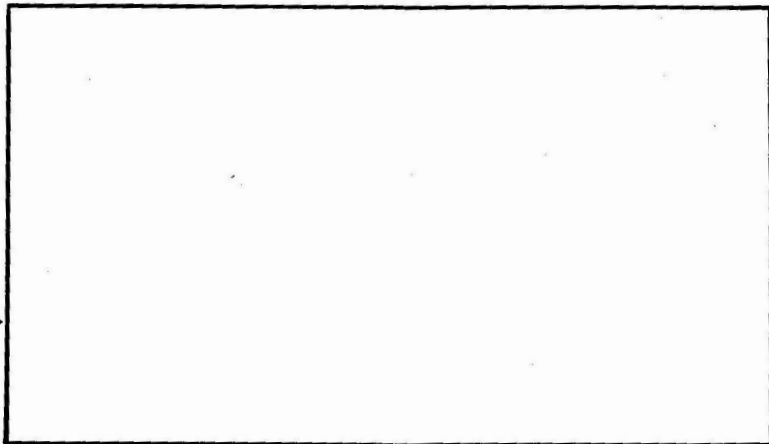

© 1965 Instructive Products Corp.

The following set of transparencies were made in the library from a commercially prepared set of transparency masters.

Notes:

All transparencies were made as listed in the master sheet and mounted. The images are clear with black lettering. All are mounted on standard 19 x 25 centimeter frames. Overlays are attached where appropriate.

Description page of transparency masters:

3R
BRAND
© 1964

**PLANNING, SELECTING, SERVING, AND EATING FOOD
HOME ECONOMICS PACKET NUMBER 1
for overhead projection**

by K. C. Heggem
Skyline High School*Idaho Falls, Idaho

CONTENTS OF PACKET

Body needs food for	IA
A daily food need:	
Milk	IB
Meat	IC
Vegetables, fruit	ID
Bread, cereal	IE
When planning a party	IF
Using a recipe	IG
Beef cuts chart	IH
Tender cuts of beef chart	II
Less tender cuts of beef chart	IJ
Pork cuts chart	IK
Veal cuts chart	IL
Lamb cuts chart	IM
Sizes of eggs	IN
Place setting:	
Snack and breakfast	IO
Dinner and luncheon	IP
Overlay:	
A family dinner	IQ
Word description	IR
Informal tea	IS
Buffet	IT
Table etiquette:	
The way we eat	IU
Table talk	IV
Table posture	IW
Using a fork and knife	IX
Soup spoon and finishing meal	IY
Finger foods	IZ
Terms to define	1AA,1BB
Abbreviations	1CC
Equivalent measures	1DD
Size in canned foods	1EE

Title on file folder:

ANIMALS OF AFRICA

Notes on format:

Each of the ten transparencies in the folder was produced in the Bloomington North High School Media Center by the media staff using old magazines and the color-lift technique. The pictures are of various sizes but the outside dimensions of the mounts are standard at 10" x 12". The quality of the transparencies is excellent. Animals pictured are: monkey, tiger, giraffe, hyena, hippopotamus, elephant, rhinoceros, zebra, lion, gazelle. The Bloomington North High School media staff produced the transparencies during the 1972-73 school year. The media staff was so pleased with the work that it was decided to keep the set together in a folder.

A single transparency, 10 x 12 in. was made to illustrate the electoral votes in the U.S. A U.S. map was traced from a book and the number of electoral votes was drawn within the boundaries of each state. A colored overlay was then prepared which showed those states without controlling power.

The transparency is entitled: **ELECTORAL VOTES.**

No production date is listed, however, it is believed to have been made before 1970. The transparency is hand-made and is not a good example of skillfully drawn graphics.

Videocassette box label:

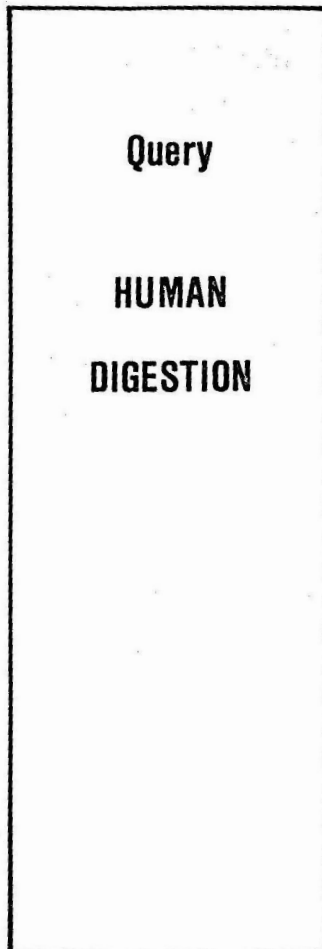

Notes on format:

Roger Query of the Hartford School of Medicine produced this sound videocassette with the assistance of his medical students in the fall semester of 1972. The production was so successful that the videotape has been used many times since. The library wishes to catalog the cassette into their permanent collection.

The cassette is 60 min. in length and is in color. The size of the tape is 3/4".

The library has a JCV VCR Model CP-5000 U/Player

Since the videocassette was made in the U.S., it is the standard 525/60 NTSC

Videocassette label:

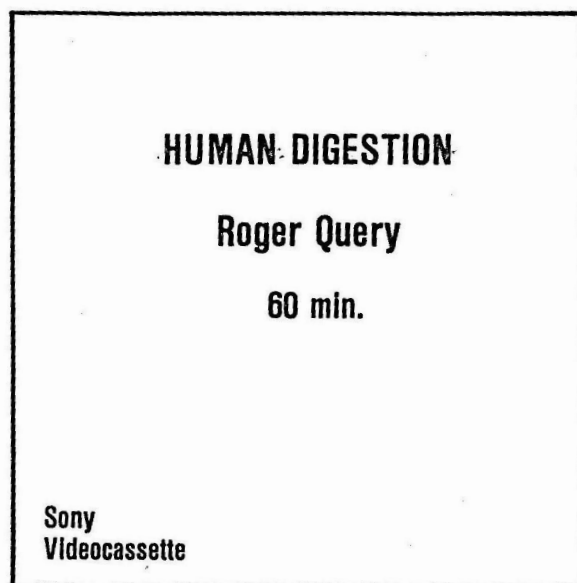

Box cover and accompanying guide cover:

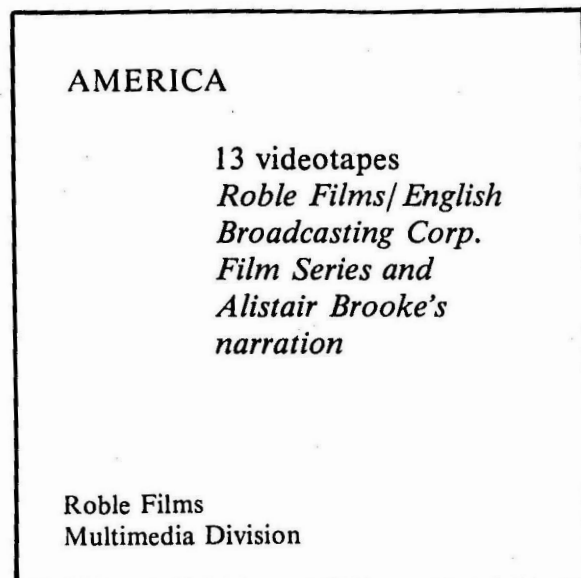

Title page of teacher's guide:

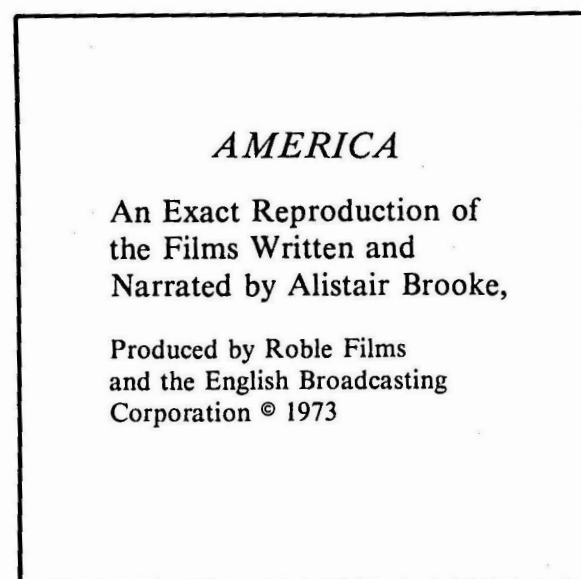

Sample reel label:

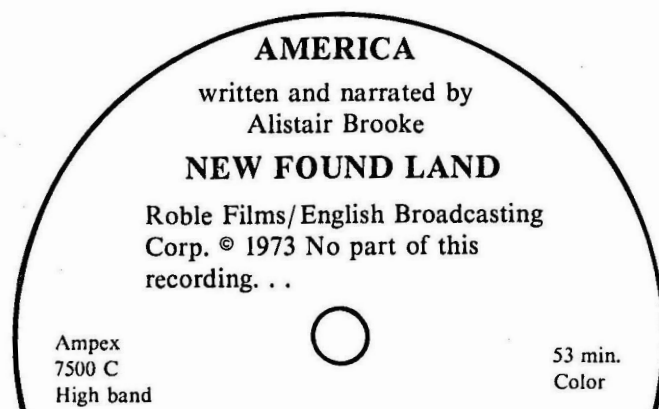

Titles in the series:

1. New Found Land
2. Home Away from Home
3. Making a Revolution
4. Inventing a Nation
5. Gone West
6. A Fireball in the Night
7. Domesticating a Wilderness
8. Money on the Land
9. The Huddled Masses
10. Promise Fulfilled and Promise Taken
11. The Arsenal
12. The First Impact
13. The More Abundant Life

Notes on format:

Each tape is 53 min. in length. Commercials from the original television presentation are deleted. Each program in the series is on a separate 1" reel.

Sample title on videotape:

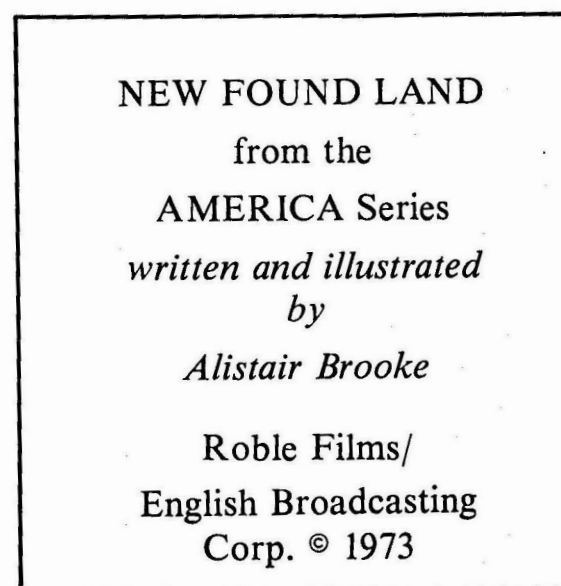

Videotape box:

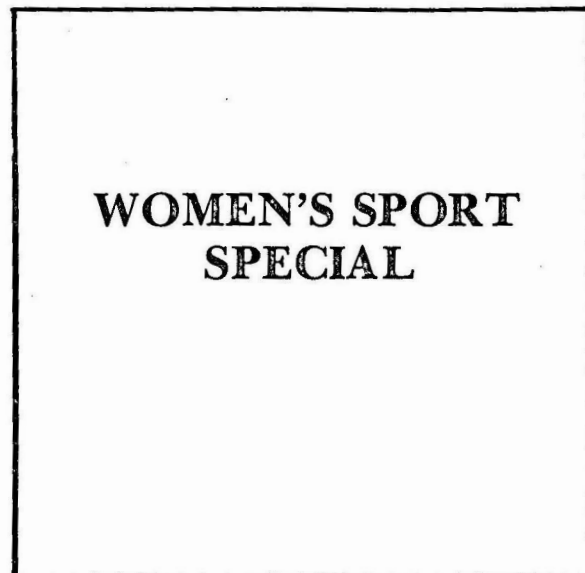

Videotape label:

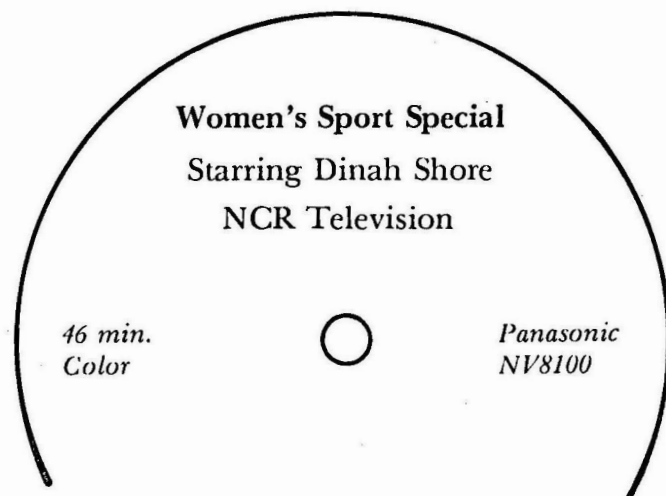

Notes on format:

This 1/2 inch tape, taken from the television broadcast, has no title appearing on the screen. Announcer says: "NCR Wide Wide World of Sports brings you this women's Sports Special starring Dinah Shore . . ."

The special was broadcast Jan. 23, 1974.

Credits at the conclusion of the tape:

Producer: Ralph Rable
Writer: Art Brush
Special Effects: Ron Bowley
Sound: Ezra Fifer
Lighting: Edward Bobinski
etc.

Summary: This sports special consists of highlights of the Colgate-Dinah Shore Golf Classic played in California in 1974.

Sample videotape box:

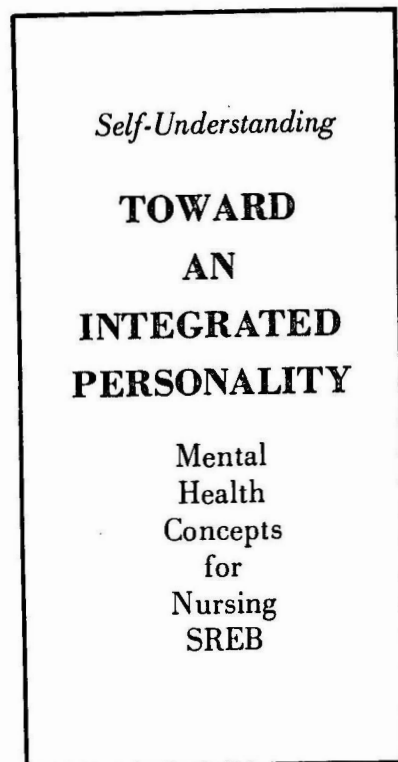

Sample videotape label:

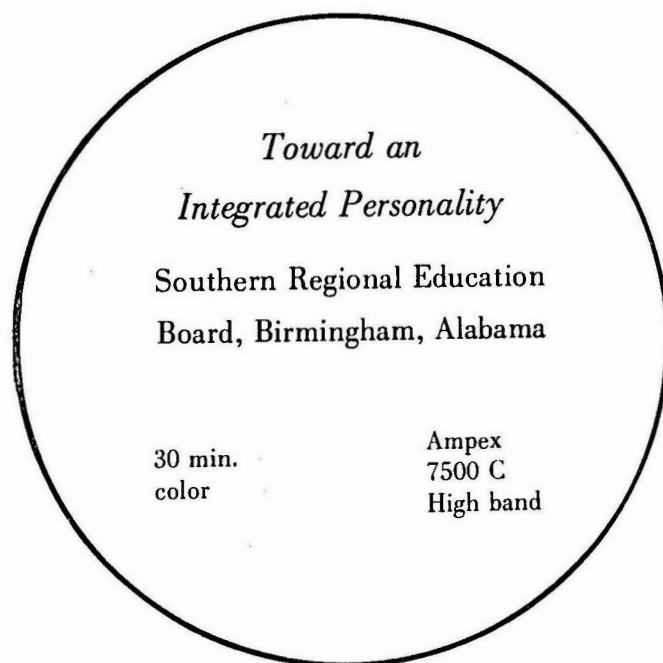

Notes on format:

The library has purchased seven videotapes in the series "Self- Understanding." The titles are:

1. Introduction to the Series
2. Developing a Self-Concept
3. The Process of Becoming
4. Toward an Integrated Personality
5. Perception of Reality
6. The Autonomous Self
7. The Key to Mastery of Environment

"Self-Understanding" is one of four sets of videotapes in the series "Mental Health Concepts for Nursing" produced in 1975. Each videotape is on one reel (1/2 inch tape) and is in color. Each program is 30 minutes in length.

Credits at the conclusion of the tape:

Produced for the Southern Regional
Education Board, Birmingham, Alabama. . .
at WEDU-TV in Tampa, Florida.
Research consultant: Winifred H.
Griffin, R.N., D.Sc.
On-camera teacher: Cynthia A. Strazis,
Dept. of Nursing, DeKalb Junior College
in Birmingham, Alabama.

(1)
813'5'4 White, Elwyn Brooks.
Charlotte's web (Audiorecord) Roadways of
or Sound, matrix no. Z4RM-016-Z4RM-023. c1962
4 discs (12 in.) 33 1/3 rpm. mono.
Pic E.B. White reads his story for children.
Cover by Garth Williams.

[1. Pigs - Stories. 2. Spiders - Stories]
I. Title.

(2)
811'5'4 Rees, Ennis.
The song of Paul Bunyan and Tony Beaver
(Audiorecord) Talking Arts, TA 954. c1964.
1 disc (12 in.) 33 1/3 rpm. mono.
Poem read by the author.
Notes by the author on album cover.

1. Bunyan, Paul - Poetry. 2. Beaver, Tony -
Poetry. [1. Bunyan, Paul - Poetry. 2. Beaver,
Tony - Poetry] I. Title.

(3)
782.8'5'54 Rodgers, Richard.
[Oklahoma. Selections] (Audiorecord)
Oklahoma. Original motion picture soundtrack.
Music by Richard Rodgers; book and lyrics by
Oscar Hammerstein II. Ropitol, WAO 595. c1955.
1 disc (12 in.) 33 1/3 rpm. stereo.
Film musical, starring Gordon MacRae and others.

1. Moving-picture music - Excerpts. [1. Operetta.
2. Musical revues, comedies, etc.] I. MacRae, Gordon.
II. Oklahoma (Motion picture)

(4)
784.3'06'12 Colors of the night: the best of Judy
Collins (Audiorecord) Zebulon Records
TZ 55030. c1972.
1 tape cassette. stereo.
Songs performed by Judy Collins.
Contents.- Someday soon.- Since you asked.-
My father.- Sons of.- Suzanne.- Farewell to
Tarwathie.- Both sides now.- Who knows where the
time goes.- Sunny Goodge street.- Albatross.- In
my life.- Amazing Grace.
1. Music, Popular (Songs, etc.) [1. Music,
Popular (Songs, etc.)] I. Collins, Judy.

(5)
785.8'52 Greensleeves (Audiorecord) RBA,
LSC-2719. c1964.
1 disc (12 in.) 33 1/3 rpm. stereo.
Morton Gould Orchestra; Morton Gould,
conductor.
Contents.- Fantasia on "Greensleeves", Fan-
tasia on a theme by Thomas Tallis, and English
folk song suite, by Vaughan Williams.- London
suite, by Coates.

1. String orchestra music. 2. Folk-songs, English.
3. Suites (Orchestra) [1. Orchestral music. 2. Folk
songs, English] I. Gould, Morton. II. Vaughan Williams,
Ralph. Fantasia on Greensleeves. III. Vaughan Williams,
Ralph. Fantasia on a theme by Tallis. IV. Vaughan Williams,
Ralph. Folk song suite. V. Coates, Eric. London suite.

In this case the label does not give the collective title present on
the album cover (both front and reverse side). Technically, according
to Weils, two main entry cards should be made, but the cataloger has
chosen to accept the collective title as a simpler method.

(6)
785.6'621'04 Gershwin, George.
[Works, instrumental. Selections] (Audiorecord)
Levant plays Gershwin. Colmania VL 700. c1965.
1 disc (12 in.) 33 1/3 rpm. mono.

Oscar Levant, piano.
Contents.- Rhapsody in blue (Philadelphia
Orchestra; Eugene Ormandy, conductor)- An Amer-
ican in Paris (New York Philharmonic Symphony
Orchestra; Artur Rodzinski, conductor)- Concerto
in F for piano and orchestra (New York Philharmonic
Symphony Orchestra; Andre Kostelanetz, conductor)

1. Concertos (Piano) 2. Piano with orchestra.
3. Orchestral music. [1. Orchestral music. 2. Piano
music] I. Levant, Oscar. II. Philadelphia Orchestra.
III. Ormandy, Eugene. IV. New York Philharmonic
Symphony Orchestra. V. Rodzinsky, Artur. VI. Kostel-
anetz, Andre. VII. Title: Rhapsody in blue.
VIII. Title: Concerto in F. IX. An American in Paris.
X. Title.

(7)
784.4'973 American favorite ballads (Audiorecord)
Folkservice Records FA 2320. c1957.
1 disc (12 in.) 33 1/3 rpm. mono.
Ballads sung by Pete Seeger accompanying
himself on the guitar.
Descriptive notes inside pocket.
1. Ballads, American. [1. Ballads, American]
I. Seeger, Peter.

Alternative entry under performer:

784.4'973 Seeger, Peter, performer.
American favorite ballads (Audiorecord)
Folkservice Records FA 2320. c1957.
1 disc (12 in.) 33 1/3 rpm. mono.
Ballads sung by Pete Seeger accompanying
himself on the guitar.
Descriptive notes inside pocket.

101

1. Ballads, American. [1. Ballads, American]
I. Title.

(8)

785.1'1'52 Schubert, Franz Peter.
 [Symphony, D. 759, B minor] (Audiorecord)
 Symphony no. 8 in B minor (Unfinished)
 RBA Y30314. [197-]
 1/2 disc (12 in.) 33 1/3 rpm. stereo.

With: Beethoven, Ludwig van. Symphony No. 5 in C minor, op. 67.
 New Jersey Philharmonic; Bruno Walter, conductor.

1. Symphonies. [I. Symphonies] I. New Jersey Philharmonic Orchestra. II. Walter, Bruno.

785.1'1'52 Beethoven, Ludwig van.
 [Symphony, no. 5, op. 67, C minor] (Audiorecord)
 Symphony no. 5 in C minor, op. 67. RBA Y30314. [197-]
 1/2 disc (12 in.) 33 1/3 rpm. stereo.

With: Schubert, Franz Peter. Symphony no. 8 in B minor (Unfinished)
 Radio City Symphony Orchestra; Bruno Walter, conductor.

1. Symphonies. [I. Symphonies] I. Radio City Symphony Orchestra. II. Walter, Bruno.

Separate entries for works issued without a collective title.

(9)

785.6'621'04 Brahms, Johannes.
 [Concerto, piano, no. 1, op. 15, D minor] (Audiorecord)
 Concerto in D minor for piano and orchestra, op. 15.
 Colmandia VL 5704. [1962]
 1 tape (7 in. reel) 7 1/2 ips. stereo.

Rudolph Serkin, piano; Philadelphia Orchestra, Eugene Ormandy, conductor.
 Pamphlet included: "The complete musician; an appreciation of Rudolf Serkin" by Irving Kolodin.

1. Concertos (Piano) [I. Piano music] I. Serkin, Rudolf. II. Philadelphia Orchestra. III. Ormandy, Eugene.

(10)

785.8'54 Copland, Aaron.
 [Rodeo, Suite] (Audiorecord)
 Four dance episodes from "Rodeo".
 Billy the Kid (excerpts) Banden Records CAS-911. [1960]
 1 disc (12 in.) 33 1/3 rpm. stereo.

Chicago Symphonic Orchestra; Leonard Bernstein, conductor.

1. Suites (orchestra) 2. Ballets - Excerpts. [I. Orchestral music] I. Copland, Aaron. Billy the Kid. Suite. II. Chicago Symphonic Orchestra III, Bernstein, Leonard. IV. Title: Rodeo. V. Title: Billy the Kid.

(11)

910 Randall talking map (Audiorecord)
 Arthur Record Productions for C. S. Randall and Co. [19-]
 1 disc (7 in.) 45 rpm., and 1 map. col. 33 x 50 in.

Title on map: Randall international map of the world.
 Mercator's project.
 Elementary.

1. Civilization, Modern - 20th century. [1. Civilization, Modern. 2. Geography]

(12)

785.6 Bach, Johann Sebastian.
 [Concerti grossi] (Audiorecord)
 Brandenburg concerti. Musical Heritage Company MKC 529-530. [1963]
 2 discs (12 in.) 33 1/3 rpm. stereo.

Pro Arte Chamber Orchestra of Munich; Kurt Redel, conductor.
 Contents.- No. 1, F major.- No. 3, G major.- No. 6, B \flat major.- No. 2, F major.- No. 4, G major.- No. 5, D major.
 Album cover title: Six Brandenburg concerti.

1. Concerti grossi - To 1800. [I. Orchestral music] I. Pro Arte Chamber Orchestra of Munich II. Redel, Kurt. III. Title. IV. Title: Six Brandenburg Concerti.

In this example, there are three variations of the title. That closest to the contents (the record label) was selected as the main entry.

(13)

785.8'52 Grieg, Edvard Hagerup.
 [Peer Gynt (Suite) no. 1-2] (Audiorecord)
 Peer Gynt suites, op. 46 and op. 55.
 Mox QUPL 512.410. c1973.
 1/2 disc (12 in.) 33 1/3 rpm. quad.

With: Bizet, Georges. L'Arlesienne suites, no. 1 and no. 2.
 Bamberg Symphony; Jonel Perlea, conductor.

1. Suites (Orchestra) [I. Orchestral music] I. Perlea, Jonel. II. Bamberg Symphony Orchestra. III. Title.

785.8'52 Bizet, Georges.
 [L'Arlesienne. Suite no. 1-2] (Audiorecord)
 L'Arlesienne suites, no. 1 and no. 2.
 Mox QUPL 512.410. c1973.
 1/2 disc (12 in.) 33 1/3 rpm. quad.

With: Grieg, Edvard Hagerup. Peer Gynt suites, op. 46 and op. 55.
 Bamberg Symphony; Courand, Marcel, conductor.

1. Suites (Orchestra) [I. Orchestral music] I. Courand, Marcel. II. Bamberg Symphony Orchestra. III. Title.

(14)

909.82'7 Living history cassettes (Audiorecord)
Universal Encyclopedia/ CRS News Audio
Resource Library, 1972-

Library has:
Jan.1973-

1. History, Modern - 1945- [1. History,
Modern - 20th century - Sources]

(15)

810'.772 Literary map of Indiana (Chart)
Indiana Council of Teachers of
English [and] The Indiana College
English Association, c1956.
1 chart. col. 36 x 24 in.

1. Authors, American. 2. Literary
landmarks - Indiana. [1. Authors, American.
2. Indiana - Bio-bibliography. 3. Literary
landmarks - Indiana]

(16)

582'.13'097 Eastern North American wildflowers (Chart)
R.R. Roberts Nature Corp., c1971.
2 charts. col. 60 x 100 cm. (Roberts aids)

1. Wild flowers - North American, Eastern.
[1. Wild flowers] I. Series.

(17)

598.2'97 Bird chart (Chart) Petersen's
Bird Society [19--]
1 chart. col. 66 x 100 cm.

Guide (15 p.) prepared by Shirley
Wright.

1. Birds - North America.
[1. Birds - North America]

(18)

629.22'22'0973 Antique automobiles (Chart) B&B Div.
Mark Oil Corp. [19--]
1 chart. col. 25 x 37 in.

1. Automobiles - History.
[1. Automobiles - History]

(19)

808.5'43 Create your own story: fairyland, pirates,
haunted houses, space (Diorama)
Gessel Creative Products, c1969.
various pieces. col.

Guide with four sample stories.
Summary: Four different backdrops and
various standup figures for storytelling.
The purpose of the diorama is to promote
language expression.

1. Story-telling. [1. Storytelling]

(20)

296.4'1 Sabbath; religion in life (Filmstrip)
Association of American Jewish
Congregations, 1968.
1 roll. col.

Title on accompanying materials:
A Jewish sabbath.
Summary: Describes the development of
Sabbath customs in the Jewish home.
General.

1. Sabbath (Jewish law) 2. Jews - Rites and
ceremonies. [1. Sabbath. 2. Jews - Rites and
ceremonies] I. Title: A Jewish sabbath.

(21)

398.2'452 Animals in fables (Filmstrip)
SRE Films, 1965.
4 rolls (36 fr. each) col.,
and 2 audiodiscs (18 min. each) (cataloged as a set)

Study guide (35 p.)
Contents.- The squirrel and his friends.-
How the squirrel saved the grapes.- Adventures
of a little skunk.- Glasses for a raccoon child.
Primary.

1. Fables. [1. Fables] I. Title analytics.

398.2'452' The Squirrel and his friends (Filmstrip)
93232 SRE Films, 1965.
36 fr. col., and 1/2 audiodisc (9 min.) (cataloged as
(Animals in fables) a single item)

Study guide (35 p.)
Primary.

1. Fables. [1. Fables] I. Series.

(22)

636 Animals to learn about (Filmstrip)
Educational Resources Films, c1961.
12 filmstrips. col.

Captions.
Collaborator: Grace Storm.
Contents.- My dog Sandy.- Playful kittens.-
Cows on the farm.- Prince the riding horse.-
Pigs on the farm.- The woolly sheep.- A goat
family.- Mother duck and her friends.- Chickens
on the farm.- Mother gray squirrel.- Mother rabbit
and her family.- Let's look at birds.

1. Animals. [1. Animals]

- 917.2 Lee, Richard B. (23)
 Families in Central America (Filmstrip) 248'.82
 Script and narration by Richard B. Lee. Made by Graded Instruction. Distributed
 Photographed by Richard B. Lee and Irven by Audio Graphics [19--]
 309.1'72 De Vore. Smith Educational Corp., 1971. 67 fr. col. and 1 audiodisc (5 min.)
 4 rolls. col., and 4 audiotape cassettes. (cataloged as a set)
- 4 Teacher's guides (32 p. each)
 Contents.- A banana-growing family of Honduras.- A village family of Guatemala.- A modern city family of Mexico.- A sisal-weaving family of Yucatan.
1. Honduras - Social conditions. 2. Guatemala - Social conditions. 3. Mexico - Social conditions. 4. Yucatan, Mexico - Social conditions.
 [1. Honduras - Social conditions. 2. Guatemala - Social conditions. 3. Mexico - Social conditions. 4. Yucatan, Mexico - Social conditions]
 I. Title analytics. II. Title.
- 917.283 Lee, Richard B. 398.2'45
 A banana-growing family of Honduras (Filmstrip) La Fontaine, Jean de
 Script and narration by Richard B. Lee. Photographed by Brian Wildsmith. Easton Woods #154, c1963, 1966.
 309.1'7283 Educational Corp., 1971. 1 roll. col.
 57 fr. col., and 1 audiotape cassette (6 min.) (Families in Central America)
 Teacher's guide (32 p.) (cataloged as single items)
1. Honduras - Social conditions. [1. Honduras - Social conditions] I. Series. II. Title.
1. Fables. [1. Fables. 2. Hares - Stories. 3. Lions - Stories. 4. Rats - Stories. 5. Tortoises - Stories] I. Wildsmith, Brian, illus. II. Title. III. Title: The hare and the tortoise.
- Catalogers may wish to individually box and shelve each of the filmstrips in this set to improve browsability as demonstrated in the call numbers.
- 808.1 What is poetry (Filmstrip) (24) 428.3
 Hoffman Records HFC-501, c1970. Picture-word cards (Flash card)
 10 rolls (40 fr. each) col., Marrard Publishing Co. [19--]
 10 audiodiscs (9 min. each) and 150 cards. b&w. 3 x 2 in.
 30 duplicating masters.
 Teacher's guide (50 p.)
1. English language. [1. English language] I. Title.
1. Poetics. [1. Poetics]
- 614.7'12 Automobiles: great contributors to smog (25) 428.3
 (Filmstrip) New York Air Resources Board in association with the New York Dept. of Public Health. Made by Roberts Productions, 1965.
 155 fr. b&w, and 1 audiodisc (20 min.)
 Discussion guide (30 p.)
 Credits: Advisor, John R. Eales; special consultant, John S. Urlaub; coordinator, Ruth S. Hartman.
 Summary: Explains what smog is, what causes it, what the automobile driver can do to lessen it, and what New York law requires regarding smog control devices on automobiles.
1. Automobile exhaust gas. 2. Motor vehicles - Pollution control devices. 3. Smog. [1. Automobiles - Pollution control devices. 2. Automobiles - Laws and regulations. 3. Air - Pollution - U.S.]
 I. Title: Smog.

Second title card should be made if the filmstrip will be housed in the original container, or the container title can be changed to agree with the filmstrip title.

- (30)**
- 371.39'44 Tutorcard programs (Flash card)
Enrichment Reading Company of
America, 1970.
12 sets of cards (54 cards each) col.
- Contents.- Kindergarten and first grade
vocabulary.- Pre-school and kindergarten
reading readiness.- Equivalent coins.-
Matching.- First grade consonant sounds.-
Kindergarten and first grade common terms.-
Alphabet recognition and sequencing.-
Vowels.- First grade science.- Second grade
science.- First grade and second grade social
studies.- First grade and second grade mathematics.
1. English language. 2. Science. 3. Social
sciences. 4. Mathematics. [1. English language.
2. Science. 3. Social sciences. 4. Mathematics]

When cataloged as a series, this set is very difficult
to classify and unless analytics are made for each title
within the set, the subject headings would need to be
so broad as to be useless.

- (31)**
- 421.52 Kingsbury, Marion.
Go fishing sound game; a game
to teach children the consonant sounds
(Game) Remedial Education Center, c1968.
60 playing cards. col. (1st series:
consonant sounds)
- Rule directions card.
1. English language - Pronunciation.
[1. English language - Pronunciation]
I. Title. II. Series: Consonant sounds.

- (32)**
- 301.42'7 Schild, Erling O.
Old/young: the generation gap (Game)
By Erling O. Schild and Sarane S. Boocock.
Serie Educational Games, Ind., 1973.
Various pieces.
- Summary: The objective of this simulation
game for 4-6 players is to teach ways of turning
conflict between teenagers and their parents
into understanding.
1. Domestic relations. [1. Domestic
relations] I. Boocock, Sarane S., jt. auth.
II. Title.

- (33)**
- 328.73 Coleman, James S.
Game of democracy (Game)
National 4-R Club Foundation, c1966.
20 ace cards, 52 constituency cards,
8 issue cards, 20 occupation cards, 66
regional cards, 6 rules, 88 work sheet.
- Leader's handbook.
Contents.- Legislative session.- Citizens'
action meeting.- Representative democracy.- A
legislator's own convictions.- The power of the
floor leader in a legislature.- Passage of
legislative program.- Committee structure in the
legislature.- Taxation and public expenditure.
1. Legislation - U.S. [1. Legislation]
I. Title.

- (34)**
- 574.5 The Environment of man (Game)
Super-Cola, c1970.
2 simulation games. various pieces.
- Contents.- Rescue in space.- Make
your own world. (cataloged as
a set)
Teacher's manual.
1. Ecology. 2. Space rescue operations.
[1. Ecology. 2. Space rescue operations]
1. Title: Rescue in space. II. Title: Make
your own world.
- 629.45'85 Rescue in space (Game)
Super-Cola, c1970.
various pieces. (The environment
of man)
- Teacher's manual.
1. Space rescue operations. [1. Space
rescue operations] I. Series.

(Each game cataloged
separately. Teacher's
manual would be
duplicated or an addi-
tional copy requested
from the company)

- 574.5 Make your own world (Game)
Super-Cola, c1970.
various pieces. (The environment
of man)
- Teacher's manual.
1. Ecology. [1. Ecology] I. Series.

- (35)**
- 525 World ocean (Globe) Relief,
c1970.
1 relief globe. col. 12 in.
in diameter, and 2 audiodiscs (7 in.)
33 1/3 rpm. mono.
- 1:41,849,600.
Audiodisc titles: The land of Mr.
Earth; The oceans of Mr. Earth.
Booklet (13 p.)
1. Earth. 2. Physical geography.
[1. Earth. 2. Physical geography]

- (36)**
- 523.8 Celestial globe (Globe)
Brock Map and Globe Corp. 1645C.
[1972?]
1 globe. col. 16 in. in diameter.
- Manual (16 p.)
Table stand mounting.
1. Stars. [1. Stars]

- (37)**
- 525 Physical-political terrestrial globe (Globe)
Mark F. Bram Co. C1264 [1969?]
1 globe. col. 16 in. in diameter.
- 1:31,680,000.
Horizon ring cradle mounting.
Illuminated.
1. Earth. [1. Earth]

(38)

- 523 Vast worlds: earth, moon, heavens (Globe)
Renoyer-Heppert MXD6352, c1974.
3 relief globes. col. 6 in. in diameter
(The globe library)
- Three manuals.
Cradle stands.
1. Earth. 2. Moon. 3. Stars. [1. Earth.
2. Moon. 3. Stars] I. Series.

(39)

- 640.73 Wise spending (Kit)
Wolcott Forward, c1971.
1 audiodisc, 2 filmstrips, 30
garment hangtags, 100 problem cards,
10 role playing scripts, 26 reading
books.
- Teacher's guide (100 p.)
Credits: General editor, Arthur Startz;
consultants, Margaret Reiss and Daniel
C. Smith.
1. Consumer education. [1. Consumer
education]

(40)

- 200 Christianity (Kit) Plaza Educational
Corp., c1973.
2 filmstrips, 2 audiotape cassettes,
2 audiodiscs, 20 reprints.
- Soundtrack on audiotape cassettes and
audiodiscs are identical.
Reprint (15 p.) from Plaza Magazine, June
13, 1955 entitled: The law of Christianity.
1. Christianity. [1. Christianity]

Optional: Catalog as a filmstrip and treat reprints as ephemeral materials.

(41)

- 917.1 Canada (Kit) U.S. Geographical Society,
c1968.
1 booklet. col. (64 p.) and 1 doll
5 in. (Around the world program)
- Booklet published by Nelson Doubleday
Inc., c1968.
1. Canada - Description and travel.
[1. Canada - Description and travel]
I. Series.

(42)

If the cataloger treats the description like that of audiorecords and considers this kit as having no collective title, two main entry cards would be made.

- 398.2'0966 How Talu the elephant got his tusk back;
A West African folk tale (Kit)
Rainbow Educational Corp. MK1900.
c1973.
1/2 audiotape cassette, 4 puppets, 4 study
prints (one side)

With: Life in West Africa.
Teacher's manual.

1. Folklore - Africa, West. [1. Folklore -
Africa, West]

- 398.2'0966 Life in West Africa (Kit)
Rainbow Educational Corp. MK1900.
c1973.
1/2 audiotape cassette, 4 study prints (one
side)

With: How Talu the elephant got his tusk back.
Teacher's manual.

1. Africa, West - Description and travel.
[1. Africa, West - Description and travel]

A combined main entry card could also be made as follows:

- 398.2'0966 How Talu the elephant got his tusk back;
A West African folk tale. Life in
West Africa (Kit) Rainbow Educational
Corp. MK1900. c1973.
1 audiotape cassette, 4 puppets, 4 study
prints (two sides)

Teacher's manual.

1. Folklore - Africa, West. 2. Africa,
West - Description and travel. [1. Folklore -
Africa, West. 2. Africa, West - Description
and travel] I. Title: Life in West Africa.

(43)

This example provides an interesting problem. The cataloger is almost bound to catalog the materials as a set with one Dewey number even though Life in West Africa belongs in the 916's. The producers probably intended that the material be used together, but it need not be. According to Weihs' rule concerning the cataloging of materials as individual items or sets (p. 5), it might be advantageous to break up this kit into two separate components. This would be possible by purchasing an additional set of study prints and another cassette, but it would also be possible to split the study prints using a graphics trick of laminating both sides with plastic and tearing each study print apart to make two separate surfaces which would then be mounted on heavy railroad board. One side of the cassette could then be duplicated to complete the second kit. In this case, the description would be:

- 398.2'0966 How Talu the elephant got his tusk back; A West African folk tale (Kit) Rainbow Educational Corp. MK1900. c1973. 1/2 audiotape cassette, 4 puppets, 4 study prints (one side) Teacher's manual. 1. Folklore - Africa, West. [1. Folklore - Africa, West]
- 916.6 Life in West Africa (Kit) Rainbow Educational Corp. MK1900. c1973. 1/2 Audiotape cassette, 4 study prints (one side) Teacher's manual. 1. Africa, West - Description and travel. [1. Africa, West - Description and travel]

- 92 Norman, Robert. John Phillip Sousa (Kit) By Robert Norman and Stephen Wright. Randhouer, c1972. B 1 audiodisc, 2 filmstrips, 2 study prints. (Great composers series) or 785'.092'4 Teacher's guide (56 p.) Small study print - (9 x 12 in.) Large study print - (16 x 20 in.) Elementary; secondary. 1. Sousa, John Phillip. [1. Sousa, John Phillip] I. jt. auth. II. Title. III. Series.

Note: This kit could easily be broken up by treating the small study print as a picture to be filed in the picture file and the large study print could be cataloged as a filmstrip. In this case, the descriptions should be:

- 92 Norman, Robert. John Phillip Sousa (Filmstrip) By Robert Norman and Stephen Wright. Randhouer, c1972. B 2 rolls. col., and 1 audiodisc (Great composers series) or 785'.092'4 Teacher's guide (56 p.) Correlated with study print of the same title. 1. Sousa, John Phillip. [1. Sousa, John Phillip] I. jt. auth. II. Title. III. Series.
- 92 John Phillip Sousa (Picture) Randhouer, c1972. or 1 study print. col. 16 x 20 in. (Great composers series) B Correlated with the filmstrip of the same title by Robert Norman and Stephen Wright. or 785'.092'4 1. Sousa, John Phillip. [1. Sousa, John Phillip] I. Title. II. Series.

(in this case the small picture considered ephemeral)

(this card assumes that no identification of artist was found)

(44)

- 552.1 Kessel, David. [Rocks] (Kit) [1965] 1 booklet, 4 jars of rock samples, 100 slides. Instructions for discussion leader. Includes 4 types of rock samples: volcanic, plutonic, metamorphic, and sedimentary. 1. Rocks. [1. Rocks]

Note: Title chosen by the cataloger should be put on the box and appended to the contents.

Note: Main entry could have been by title. However, Kessel was chosen as "primarily responsible" for the creation of the work.

- (45)**
- 398.8 Dure, Beth ed.
Songs from Mother Goose (Kit) Edited
or by Beth Dure and Lucille Ladd. Saymar [1973?]
784.6'24 1 audiotape cassette, 15 booklets, 2 filmstrips,
15 sentence strips, 8 study prints and 8 verse cards
(in 4-ring binder), 125 vocabulary cards.
- Teaching suggestions on back of study prints.
Credits: Narrated and sung by Marni Brown.
Orchestrated by Edward B. Lorey. Designed and
illustrated by Paul Smith.
Contents.- Little Jack Horner.- Hot cross buns.-
Simple Simon.- Hey diddle diddle.- Jack Sprat.-
Old Mother Hubbard.- Baa baa black sheep.- Little
Bo Peep.
Primary.
1. Mother Goose - Songs & music. [1. Nursery rhymes -
Songs and music] I. Ladd, Lucille. II. Title. III.
Title analytics.
- (46)**
- 513'.2 Math principles (Kit)
Winger, [1970?]
18 audiotape cassettes, 30 booklets,
12 filmstrips, 40 flash cards, 1 floor
game, 1 gameboard, 15 geometric shaped insets,
4 inlay forms, 30 number lines, 100 playing
cards, 12 response cards, 132 study prints,
wax markers.
- Teacher's guide.
Primary.
1. Mathematics. [1. Arithmetic]
- Notes: Cataloger may wish to include contents notlisting titles
of individual items in which case title analytics would be
appropriate. The cataloger may also wish to break up the kit
into its various components and catalog each component separately.
The order of the items in the collation will vary depending on the
precise name selected for each item.
- (47)**
- 027.8'222' Loertscher, David V.
09772 Research survey of Indiana elementary
school IMCs; IMC staff responses (Machine
readable data file) Collected by David
V. Loertscher and Phyllis Land. Indianap-
olis, Indiana State Department of Public
Instruction, 1974.
197 logical records.
1. School libraries - Indiana. [1.
Instructional materials centers - Research]
I. Land, Phyllis, jt. auth. II. Title.
- (48)**
- 029'.93 Northwestern University Computing Center
SPSS data package version 5.5 (Machine
readable data file) The Center, 1973.
2500 logical records.
- Size of file not verified.
1. Information storage and retrieval
systems - Social sciences. [1. Information
storage and retrieval systems] I. Title.
- (49)**
- 523.8 The Heavens (Map) Compiled and
drawn by Edward Bolinsky. Regional
Geographic Co., 1970.
1 sheet (printed both sides) col.
35 x 23 in.
- 10 insets.
Summary: Shows northern sky, southern
sky, constellations, and shows monthly
star charts.
1. Stars. [1. Stars]
- (50)**
- 919.8 Antarctica (Map)
U.S. Geographical Society, 1963.
1 sheet. col. 67 x 75 cm.
- 1:9,820,800.
Azimuthal equidistant projection.
Shows current and past bases, explorer
routes, elevations, etc.
1. Antarctic regions. [1. Antarctic
regions]
- (51)**
- 912 World (Map) Long's Map and
Globe Co. [c1958?]
1 sheet. col. 42 x 55 in.
- 1:33,000,000.
Mercator projection.
1. Earth - Description and travel.
[1. Earth - Description and travel]
- (52)**
- 915 Eurasia (Map) Wenshow.
Distributed in the U.S. by
Renoyer-Heppert, [196-]
1 relief map. col. 48 x 72 in.
- 1:7,500,000.
1. Physical geography - Eurasia.
2. Oceanography. [1. Physical geography -
Eurasia. 2. Physical geography - Ocean]
- (53)**
- 557.72'45 Distribution, structure, and mined areas of coal
in Vigo County, Indiana (Map) Compiled
by C. E. Wier. Indiana Department of
Conservation Geologic Survey, 1952.
1 sheet. b&w. 15 x 28 in. (Preliminary
coal map no. 1)
- 1:126,720.
1. Coal mines and mining - Indiana - Vigo Co.
[1. Coal mines and mining] I. Series.
- (54)**
- Alaska. Topographic series. 1:250,000.
- To find maps held in this series, see
the index sheet to the series in the
TOPOGRAPHIC MAPS drawer of the map case.

(55)

027.8'222'
09775 Christison, Milton Robert.
An examination of selected variables associated with elementary instructional materials centers (Microform) Dept. of Photography, University of Wisconsin. Released by University Microfilms, 73-23,057, 1973.
1 film reel. 35 mm.
Thesis - University of Wisconsin, 1973.
100 1.
Bibliography: 1. 72-77.

1. School libraries - Wisconsin. 2. School libraries - Research. [1. Instructional materials centers - Research] I. Title.

(56)

371.33 Filep, Robert T.
The impact of research on the utilization of media for educational purposes, sponsored by NDEA Title VII 1958-1968. Final report (Microform) ERIC ED042064, [1970?]
5 fiche. 10 x 15 cm.
Originally published under contract with the U.S. Office of Education by the Institute for Educational Development, 1970.
Collation of original: 273 p.

1. Audio-visual education - Research. [1. Audio-visual education - Research] I. Title.

(57)

917.3 Balme, Joshua R.
Letters on the American Republic; or common fallacies and monstrous errors refuted and exposed (Microform) Found Cause Press, 1964.
4 opaque cards. 8 x 13 cm.
Originally published by Hamilton, Adams & Co., 1863.
Collation of the original: 290 p. 19 1/2 cm.

1. United States - History - Civil War - Addresses, sermons, etc. 2. Slavery in the United States. [1. United States - History - Civil War - Addresses and essays. 2. Slavery in the United States] I. Title.

(58)

016.9173'
06'96 Historical Records Survey. New York (City)
Calendar of the manuscripts in the Schomburg Collection of Negro Literature, located at 135th Street Branch, New York Public Library (Microform) Compiled by the Historical Records Survey, Works Projects Administration, New York City, 1942. 3R Company, 1967.
1 film reel. 35 mm.

Collation of original: 513 p.

1. Negroes - Manuscripts - Catalogs. [1. Negroes - Catalogs] I. New York (City). Public Library. Schomburg Collection of Negro Literature and History. II. Title.

(59)

591.1'13 Dog blood smear (Microscope slide)
Hurlbert, Ross & Co. H2.864.
1 slide (glass) 3 x 8 cm.

1. Blood. [1. Blood]

(60)

591.3'34 Typical pig embryology set (Microscope slide) Burtax/Rambosco Science Co.
10 slides (glass) stained. 3 x 8 cm.

1. Embryology. [1. Embryology]

(61)

581.1 Basic botany set (Microscope slide)
Miarch Scientific Co.
15 slides (glass) stained. 3 x 8 cm.

1. Plant cells and tissues. [1. Botany - Anatomy]

(62)

523.2'07'8 Elementary planetarium (Model)
System & Co., SL400. [1970?]
1 piece. col.

Manual (176 p.) by John W. Gross.

1. Solar system. 2. Eclipses, Lunar. 3. Eclipses, Solar. [1. Solar system. 2. Eclipses, Lunar. 3. Eclipses, Solar. 4. Seasons. 5. Time]

(63)

92 Cherne, Leo.
The Lincoln of the final sacrifice (Model)
Salva Museum Replicas, Inc., [19--]
1 piece. bronze. 8 in.

B After the last photograph by Alexander Gardner.
or Bronze original at Lincoln Museum.

923'.1'73

1. Lincoln, Abraham, Pres. U.S., 1809-1865. 2. Sculpture, American. [1. Lincoln, Abraham, Pres. U.S. 2. Sculpture, American] I. Gardner, Alexander. II. Title.

(64)

621.3819'58 Comp-digi 1 (Model)
Montgomery House, 1965.
1 piece col.

Instruction manual (28 p.)
Parts list.

1. Computers - Design and construction. [1. Computers]

(65)

611 The Visible human (Model)
Walker Products Inc., [19--]
various pieces. col. 18 in.

Plastic scale model with stand. Transparent plastic human shell can be removed. Inner organs and bones are colored individual pieces which can be attached or removed.

1. Anatomy. [1. Anatomy]

- (66)
- 398.2 [Little red riding hood puppet] (Model)
1 piece. 18 in.
Red riding hood puppet turned upside down
becomes grandma puppet and wolf puppet.
Made by Alice McGowan, 1974.
155.5'32
or
371.4'6
- [1. Folklore]
- (67)
- 611'.12 The Heart (Model)
Rostrum Biology Model Co.
70140 & 62002. c1971.
various pieces. col., and 1
audiorecord. (Talking models)
Manual (8 p.)
1. Heart. [1. Heart] I. Series.
813'.5'2
or
Fic
- (68)
- 629.45 Apollo 11: man on the moon
(Motion picture) U.S. National Aero-
nautics and Space Administration.
Released by Columbia Pictures, 1969.
9 min. si. b&w. Super 8 mm.
Official NASA footage.
1. Project Apollo. 2. Space flight to
the moon. [1. Apollo project. 2. Space
flight to the moon]
- (69)
- 622'.382 Open pit diamond mining (Motion picture)
Zhur Institut. Released by Blackwell
Films [1973]
1 cartridge. 16 min. sd. col. Super 8 mm.
(Producing world gems)
Technicolor cartridge.
Notes on cartridge case.
Summary: Depicts the open pit mining and the
mechanical and hand processing of raw diamonds,
showing how they are extracted from the earth,
sorted, inspected, and weighed.
Secondary.
1. Diamond mines and mining. [1. Diamonds.
2. Mines and mineral resources] I. Zhur Institut.
II. Blackwell Films. III. Series.
- (70)
- 387.2 It's safe to sail (Motion picture) RVP
Television Inc., 1969.
20 min. sd. b&w. 16 mm. (Movement, no. 8)
Summary: Illustrates and discusses the
development of water transport, the different
kinds of boats and ships, their shape,
propulsion, loading, and water safety.
Elementary.
1. Boats and boating. 2. Ships. [1. Boats
and boating. 2. Ships] I. RVP Television Inc.
II. Series.
- (71)
- Looking for meaning (Motion picture)
Ron Bowley. Morwin Films, 1960.
Released in the U.S. by John Thomas
Films, 1972.
32 min. sd. b&w. 16 mm.
Title on film can: Looking for meaning in life.
Study guide.
Summary: An impetuous young man leaves his
job in a city gas station to build a cabin and
live off the land in the country. His failure
to succeed proves that more than superficial
knowledge is needed to cope successfully with
important decisions.
1. Meaning (Psychology) [1. Adjustment (Psy-
chology] I. Bowley, Ron. II. Morwin Films.
III. John Thomas Films.
- (72)
- 813'.5'2 Brown Wolf (Motion picture) Worldwide
Film Center. Released in the U.S. by
Fine Arts Films, 1965.
26 min. sd. col. 16mm.
Summary: An adaptation of Jack London's
story in which the conflict between the
refinements of civilization and the call of the
wild is dramatized as two people attempt to
possess a wild dog.
Elementary; secondary.
[1. Dogs - Stories] I. London, Jack. II. Title.
III. Worldwide Film Center. IV. Fine Arts Films.
- (73)
- 646.7'24 Treating the scalp (Motion picture) Made by
Visdex Corp. Shorne Films, c1972.
1 cartridge. 4 min. si. col. Super 8 mm.
(Your work in cosmetology)
Kodak cartridge.
Notes on cartridge case.
Summary: Illustrates procedures for giving
an oil scalp treatment.
Secondary; specialized.
1. Hair - Care and hygiene. [1. Hair - Care
and treatment] I. Visdex Corp. II. Shorne Films.
III. Series.
- (74)
- 759.13 Yearian, Beatrice M.
Fall dance #75 (Picture)
Park City, Utah, 1970.
1 painting. col. 36 x 45 in.
Abstract in acrylics.
1. Painting, American. 2. Art, Abstract.
[1. Painting, American. 2. Art, Abstract.
3. Painting, Modern - 20th century] I. Title.
- (75)
- 759.13 Moser, Lloyd V.
Taneycomb in the Ozarks (Picture)
West Lafayette, Ind., [19—]
1 painting. col. 10 x 12 in.
Watercolor.
1. Painting, American. 2. Landscape
painting, American. 3. Water-color painting -
U.S. [1. Painting, American. 2. Landscape
painting. 3. Water color painting] I. Title.

(76)
759.4 Renoir, Pierre Auguste.
On the terrace (Picture)
Kunstreis Luzern, Distributed in the
U.S. by Habrams, c1960.
1 art print. col. 18 x 26 in.

1. Painting, French. 2. Impressionism (Art)
[1. Painting, French. 2. Impressionism (Art)]
I. Title.

(77)
598.2'97 Bronson, Clark.
Portfolio of bird sketches (Picture)
Field Arts Inc., c1968.
17 pictures bound in portfolio. col.
11 x 14 in.

Subtitle: Beautiful color pictures of
seventeen North American birds which can be
removed for framing.

1. Birds - North America. 2. Drawing, Amer-
ican. [1. Birds - North America. 2. Drawing,
American] I. Title.

(78)
759.94 Masterpieces from the Samuel H. Kress
collection (Picture) National Gallery
of Art, 1956.
15 art prints. col. 11 x 14 in. (Portfolio
no. 5)

Descriptive folder (3 p.) by Fern Rusk Shapley.

1. Paintings, European. [1. Paintings]
I. Series.

(79)
599'.0967 Rie, Leonard III.
Animals of East Africa (Picture)
General Education Co. Released by E.M.
Wright & Co., c1969.
13 study prints. col. 13 x 18 in. (Nature
study prints, set no. 4)

1. Mammals - Africa, East. [1. Animals -
Africa, East] I. Title. II. Series.

(80)
598.2'97 Birds we know (Picture)
Winger Educational Training
Products, c1963.
8 study prints. col. 13 x 18 in.,
and 1 audiodisc (15 min.) (Basic science
series PS SP-100) (Talking Picture study
prints SR-509)

Contents.- Great horned owl.- Cardinal.-
Blue jay.- Redwing blackbird.- Mourning dove.-
Brown thrasher.- Robin.- Hairy woodpecker.

1. Birds - North America. [1. Birds -
North America] I. Series: Basic science series.
II. Series: Talking Picture study prints.

(81)
398.2'0942 The Three pigs (Picture)
Wallace Products Co., c1964.
10 flannel board figures. col.

Information sheet and suggestions
for use.

1. Folklore - England. [1. Folklore -
England. 2. Pigs - Stories]

(82)
593'.93'09163 [Atlantic starfish] (Realia)
1 piece. 9 in.

Collected near Miami, Florida.

1. Starfishes. [1. Starfish]

(83)
735'.29 De La Roche, Clark.
[Cypress tree root tip] (Realia)
1 piece, 25 in.

Collected from Alabama.

1. Sculpture, Modern - 20th century.
2. Sculpture, American. 3. Cypress.
[1. Sculpture, Modern - 20th century.
2. Sculpture, American. 3. Cypress]

(84)
589.2'2 Basidiomycetes (Realia)
Remyer-Heppert Co., [1972?]
1 piece. (Demonstration mount
BD15)

Contents: agaricus, fomes, lycoperdon,
olavaria.

1. Basidiomycetes. [1. Fungi]
I. Series.

(85)
Note: This card assumes that the items in the box may change
at various times. If the items are considered permanent, then
the card would read:

391'.00972 [Mexican costumes] (Realia)
1972.
or 16 pieces.
917.2 Contents: 1 shawl, 1 dress, 10
pieces of jewelry, 1 sombrero, 1
pair of sandals, 1 belt, 1 shirt.

1. Costume - Mexico. [1. Mexico -
Social life and customs. 2. Costume]

The title given by the cataloger should be listed on the box and
on each item. This information can be written on tags attached
to each article.

- (86)
- 099 [Hornbook] (Realia)
1 piece. 3 x 6 in.
- (87)
- 373.2'7 McVickery, Howard.
A time to decide (Slide)
Indiana State University Research
Foundation, c1971.
92 slides. col. 2 x 2 in., and 1
audiocassette (20 min.)
- Script.
Summary: Describes ways high school
students may gain actual experience in
industry as a part of their school day.
1. Education, Cooperative. [1. Vocational
education] I. Title.
- (88)
- 917.59'41 Liddle, Thomas E. Jr.
Key West and the Florida Keys (Slide)
Blackbay Films [19--]
26 slides. col. 2 x 2 in.
- With slide list.
1. Key West, Florida - Description.
2. Florida Keys - Description and travel.
[1. Key West, Florida - Description.
2. Florida Keys - Description and travel]
I. Title.
- (89)
- 328'.37 How a bill becomes a law (Slide)
The National Federation of Business
and Professional Women's Clubs, Inc.
Bob Cazzaca Productions [196-?]
33 slides. col. 2 x 2 in.
- Script.
1. Legislation - United States. [1. Legislation]
- (90)
- 574.5'24 Ecological succession (Slide)
Knight-Rowe Audiovisuals, c1970.
58 slides. col. 2 x 2 in. (Ecological
investigations; a biological approach)
- Captions.
Manual (52 p.)
1. Ecological succession. [1. Ecology]
I. Series.
- (91)
- 759.13 Marriott, Celia.
American art in the 20th century (Slide)
Pathfinder Inc. and the Art Institute of
Chicago, c1970.
50 slides. col. 2 x 2 in., and 1 audio-
disc (19 min.)
- Guide (10 p.) includes script.
William Barber, narrator.
Summary: An overview of abstract
expressionism and later American art styles.
1. Paintings, American. 2. Expressionism (Art)
[1. Painting, American. 2. Expressionism (Art)]
I. Title.
- (92)
- 341.24 World alignments (treaty organizations)
(Transparency) Riley Art and Film
Corp. Distributed by Eastern Educa-
tional Services, c1964.
1 sheet (4 attached overlays) col.
10 x 12 in. (World History, no. 258)
1. Regionalism (International organi-
zation) [1. Treaties] I. Series.
- (93)
- 912'.014 Reading maps (Transparency)
Instructive Products Corp., c1965.
7 sheets (attached overlays) col.
10 x 12 in. (Instructive teaching transparencies,
851 B)
- Teaching guides.
Suggestions for effective transparency pres-
entation.
1. Maps. [1. Maps] I. Series.
- (94)
- 641.3 Heggen, K. C.
Planning, selecting, serving and eating
food (Transparency) 3R, c1964.
30 sheets (attached overlays) b&w.
19 x 25 cm. (Home economics packet, no. 1)
1. Dinners and dining. 2. Table etiquette.
3. Cookery (Meat) 4. Nutrition. [1. Dinners and
dining. 2. Table etiquette. 3. Cookery - Meat.
4. Nutrition] I. Title. II. Series.
- (95)
- 599'.096 Animals of Africa (Transparency)
Blcomington North High School Media
Center, 1973.
10 sheets. col. 10 x 12 in.
- Contents.- Monkey.- Tiger.- Giraffe.-
Hyena.- Hippopotamus.- Elephant.- Rhino-
ceros.- Zebra.- Lion.- Gazelle.
1. Mammals - Africa. [1. Animals -
Africa]

(96)

Because of the dubious quality of the transparency, the most appropriate cataloging would be to file the transparency in an ephemeral file under the heading [Presidents - U.S. - Election]

If the transparency was made before 1970, that fact should be noted and recorded, since the 1970 census did affect the number of electoral votes in several states. This being true, the value of the transparency would be to make a historical comparison with the electoral votes which currently exist.

(97)

- 611.3 Query, Roger.
Human digestion (Videorecord)
The Author, 1972.
1 tape cassette. 60 min. col. 3/4 in.
Sony Videocassette. 525/60; NTSC.

1. Digestion. [1. Digestion] I. Title.

(98)

- 917.3'03 Brooke, Alistair.
America (Videorecord) Roble
Films/English Broadcasting Corp.,
c1973.
13 tapes. 53 min. ea. col. 1 in.
Ampex 7500C. High band.

1. U.S. - History. [1. U.S. - History]
I. Title.

(99)

- 796.352'73 [Women's sports special] (Videorecord)
NCR Television, 1974.
1 tape. 46 min. col. 1/2 in. (NCR
wide world of sports)

Panasonic NV8100.
Credits: Dinah Shore, star; Ralph
Rable, producer; Art Brush, writer.
Summary: Highlights of the Colgate -
Dinah Shore golf classic.

1. Golf for women. [1. Golf]
I. Colgate - Dinah Shore golf classic.
II. Series.

(100)

- 155.2 Self-understanding (Videorecord)
Southern Regional Education
Board, 1975.
7 tapes. 30 min. ea. col. 1/2 in.
(Mental health concepts for nursing)

Ampex 7500C. High band.
Credits: Research consultant, Winifred
H. Griffin; on-camera teacher, Cynthia A.
Strazis.

Contents.- Introduction to the series.-
Developing a self-concept.- The process of
becoming.- Toward an integrated personality.-
Perception of reality.- The autonomous self.-
The key to mastery of environment.

1. Psychology. [1. Psychology] I. Series.

INDEX

Number given refers to example

Accompanying data, 7, 9, 17, 19, 21, 23, 25, 26, 31, 33-36, 38, 39, 46, 62, 64, 71, 78, 81, 87-91, 93

Accompanying media

Interdependent items cataloged under dominant medium, 11, 21, 23-26, 29, 35, 67, 80, 87, 91

Audiorecords

Main entry

Collective title, 4, 5, 7
Separate entries, 8, 13
Under performer, 7
Works of one composer, 3, 6, 7, 10, 12

Notes

Contents, 4-6, 12
Names of performers, 1, 3-10, 12, 13
With note, 8, 13

Publisher

Matrix number, 1
Serial identification, 2-10, 12, 13

Uniform title, 3, 6, 8-10, 12, 13

Author as main entry, 1-3, 6, 8-10, 12, 13, 23, 27, 28, 31-33, 43-45, 47, 48, 55-58, 63, 72, 74-77, 79, 83, 87, 88, 91, 94, 97, 98

Classification

000's, 47, 48, 55, 58, 86
100's, 71, 100
200's, 20, 26, 40
300's, 21, 23, 27, 30, 32, 33, 42, 45, 56, 66, 70, 71, 81, 85, 87, 89, 92
400's, 28, 29, 31
500's, 16, 17, 34-38, 44, 46, 49, 53, 59-61, 77, 79, 80, 82, 84, 90, 95
600's, 18, 22, 25, 34, 39, 64, 65, 67, 68, 73, 94, 97
700's, 3-10, 12, 13, 43, 45, 74-76, 78, 83, 84, 91, 99
800's, 1, 2, 15, 19, 24, 72
900's, 11, 14, 23, 41, 43, 50-52, 57, 63, 85, 88, 93, 98
Add from schedules, 3, 5, 6, 9, 10, 13, 16, 21, 33, 48, 58, 60, 69, 74-76, 98

Areas, 7, 16-18, 23, 41, 42, 47, 50, 53, 55, 57, 63, 77-82, 85, 88, 91, 95, 98

Standard subdivisions, 62

Subdivision for individual languages, 28, 29

Subdivision for individual literature, 1, 2, 15, 72

Collation

Size in centimeters, 16, 17, 50, 56, 57, 59, 60, 61, 94

Size in inches, 11, 15, 18, 28, 29, 35-38, 41, 49, 51-53, 63, 65, 66, 74-80, 83, 86-93, 95, 97-99

Ephemeral materials, 54, 96

Filmstrips, 22

Filmstrips

Collation

Interdependent accompanying medium, 21, 23, 24, 26

Number of frames, 25, 26

Number of rolls, 20, 23, 24, 27

Main entry

Author, 23, 27

Series title, 21, 23

Single filmstrip title, 21-24

Title, 20, 24-26

Notes

Captions, 22

Contents notes, 21, 23

Credits, 22, 24

Summary, 20, 24, 26

Globes

Construction, 36-38

Relief, 35, 38

Scale, 35, 37

Imprint

Dates derived from outside sources, enclosed in brackets, 1, 8-12, 17, 18, 26, 28, 36, 37, 44, 52, 56, 63, 65, 75, 88

Uncertain dates, 8, 11, 17, 18, 26, 28, 36, 37, 45, 46, 51, 52, 56, 62, 63, 75, 83, 88, 89

Joint authors, 32, 43, 47

- Kits
 - Credits, 39, 45
 - Main entry
 - Author, 43-45
 - Title, 39-42, 46
 - Series, 41, 43
- Machine readable data files
 - Main entry
 - Author, 47
 - Corporate, 48
- Main entry, see Author as main entry, Title as main entry, Supplied title
- Maps
 - Cartographer, 49, 53
 - Projection, 50, 51
 - Scale, 50-53
 - Topographic, 54
- Microforms
 - Fiche, 56
 - Film, 55, 58
 - Opaque cards, 57
 - Original format, 55-58
- Models
 - Planetarium, 62
 - Puppet, 66
 - Sculpture, 63
- Motion pictures
 - Author main entry, 72
 - Producer, 73
 - Releasing agent, 69, 71, 72
 - Summary, 69, 70, 73
 - 8 mm, 69, 73
 - 16 mm, 70-72
- Pictures
 - Art originals, 74, 75
 - Art prints, 76-78
 - Flannel board figures, 81
 - Interdependent accompanying medium, 80
 - Study prints, 79, 80
- Planetarium, see Models
- Puppet, see Models
- Realia
 - Actual objects, 82, 83, 85, 86
 - Specimens, 84
- Reproduction, 55-58
- Sculpture, see Models
- Series
 - Series statements, 16, 21, 23, 34, 43, 69, 70, 73, 79, 80, 90, 94, 100
 - Used as main entry, 21, 30, 34
- Sets
 - Cataloged by item, 21, 23, 34, 43
 - Cataloged by set, 12, 14, 16, 21-24, 30, 34, 38, 40-46, 60, 61, 77-80, 87-91, 93-95, 98
- Subject headings added by the cataloger
 - Common names, 1, 27, 81, 82, 84, 86
 - Corporate names, 68
 - Proper names, 2, 23, 40-43, 45, 63, 88, 98
- Supplied title, 44, 66, 82, 83, 85, 86, 99
- Title
 - Main entry, see Title as main entry
 - Supplied title as main entry, see Supplied title
 - Uniform title, 3, 6, 8-10, 12, 13
 - Title as main entry, 4, 5, 7, 11, 14-22, 24-26, 29, 30, 34-42, 46, 49-53, 59-62, 64, 65, 67-71, 73, 78, 80, 81, 84, 89, 90, 92, 93, 95, 100
- Transparencies
 - Ephemeral, 96
 - Overlays, 92-94
- Videorecords
 - Credits, 99, 100